

EPL2
Programmer's
Manual
Programming for Page Mode
Printing

Manual No. 980352-001 Rev.D

©2003 ZIH Corp.

FOREWORD

This manual provides programming information for printers featuring Zebra's EPL2 Programming and command language, which are manufactured by Zebra Technologies Corporation, Camarillo, California.

COPYRIGHT NOTICE

This document contains information proprietary to Zebra Technologies Corporation. This document and the information contained within is copyrighted by Zebra Technologies Corporation and may not be duplicated in full or in part by any person without written approval from Zebra. While every effort has been made to keep the information contained within current and accurate as of the date of publication, no guarantee is given or implied that the document is error-free or that it is accurate with regard to any specification. Zebra reserves the right to make changes, for the purpose of product improvement, at any time.

TRADEMARKS

Zebra and EPL2 are trademarks of Zebra Technologies Corporation. All other marks are trademarks or registered trademarks of their respective holders.

REVISION HISTORY

Rev. A - This manual version coincides with Zebra printers with EPL2 firmware version 4.04.

Rev. B - This manual version coincides with Zebra printers with EPL2 firmware version 4.18.

Rev. C - This manual adds the 2746e and TR220 printer models and updates the Cash Draw Kicker command.

Rev. D - This manual coincides with most Zebra printers with EPL2 firmware version 4.28 and is available from Zebra in electronic form. Most differences in printer programming functionality are noted within this manual, but some features and command differences may have been omitted, missed or had an implementation variance or change after this manual was updated and published.

Additions and changes include: the 3842 printer model, adds USPS Planet bar code, Data Matrix bar code, RSS-14 bar code, JC command, OF command, ^ default, code commenting (the semi-colon), RTC defaults and improves PDF-417 data compaction description.

See the Zebra web site for information on Zebra Technologies printers at: www.zebra.com

Table of Contents

Introduction	1-1
Command Conventions	1-2
Basic Command Syntax	1-3
Command Editor	1-3
Placing Elements in the Print Image	1-4
Text (Fonts)	1-5
Bar Codes	1-7
Programming Sequences Affect Graphic Results	1-8

Printer Configuration	2-1
Printer AutoSense Feature	2-1
Determining Printer Firmware Version	2-2
Programming Mode Configuration	2-3
Media Detection	2-4

Command Reference	3-1
A Command - ASCII Text	3-4
Asian Character Font Sets	3-8
AUTOFR Command - Automatic Form Printing	3-9
B Command - Bar Code	3-11
B Command - RSS-14 Bar Code Specific Options	3-16
b Command - 2D Bar Code - Data Matrix Specific Options	3-20
b Command - 2D Bar Code - MaxiCode Specific Options	3-25
b Command - 2D Bar Code - PDF417 Specific Options	3-29
C Command - Counter	3-37
C Command - Cut Immediate	3-39
D Command - Density	3-40
dump Command - Enable Dump Mode	3-41
eR Command - User Defined Error/Status Character	3-42
EI Command - Print Soft Font Information	3-43
EK Command - Delete Soft Font	3-44
ES Command - Store Soft Font	3-45
f Command - Cut Position	3-50
FE Command - End Form Store	3-51
FI Command - Print Form Information	3-52
FK Command - Delete Form	3-53
FR Command - Retrieve Form	3-54
FS Command - Store Form	3-55
GG Command - Print Graphics	3-57
GI Command - Print Graphics Information	3-58
GK Command - Delete Graphics	3-59

GM Command - Store Graphics	3-60
GW Command - Direct Graphic Write	3-62
I Command - Character Set Selection	3-63
JB Command - Disable Top Of Form Backup	3-65
JC Command - Disable Top Of Form Backup- All Cases	3-66
JF Command - Enable Top Of Form Backup	3-67
LE Command - Line Draw Exclusive OR	3-68
LO Command - Line Draw Black	3-69
LS Command - Line Draw Diagonal	3-70
LW Command - Line Draw White	3-71
M Command - Memory Allocation	3-72
N Command - Clear Image Buffer	3-73
o Command - Cancel Software Options	3-74
oB Command - Cancel Auto Bar Code Optimization	3-75
oE Command - Line Mode Font Substitution	3-76
oH Command - Macro PDF Offset	3-77
oM Command - Disable Initial Esc Sequence Feed	3-79
oR Command - Character Substitution (Euro)	3-80
oW Command - Customize Bar Code Parameters	3-82
O Command - Hardware Options	3-84
OEPL1 Command - Set Line Mode	3-86
P Command - Print	3-87
PA Command - Print Automatic	3-88
q Command - Set Label Width	3-89
Q Command - Set Form Length	3-91
r Command - Set Double Buffer Mode	3-95
R Command - Set Reference Point	3-96
S Command - Speed Select	3-97
TD Command - Date Recall & Format Layout	3-98
TS Command - Set Real Time Clock	3-99
TT Command - Time Recall & Format Layout	3-100
U Command - Print Configuration (General)	3-101
UA Command - Enable Clear Label Counter Mode	3-102
UB Command - Reset Label Counter Mode	3-103
UE Command - External Font Information Inquiry	3-104
UF Command - Form Information Inquiry	3-105
UG Command - Graphics Information Inquiry	3-106
UI Command - Host Prompts/Codepage Inquiry	3-107
UM Command - Codepage & Memory Inquiry	3-108
UN Command - Disable Error Reporting	3-109
UP Command - Codepage & Memory Inquiry/Print	3-110
UQ Command - Configuration Inquiry	3-111

US Command - Enable Error Reporting	3-112
U% Command - Host Prompts/Motor Temperature	3-114
US Command - Host Prompts/Battery Status	3-115
V Command - Define Variable	3-116
W Command - Windows Mode	3-118
xa Command - AutoSense	3-119
X Command - Box Draw	3-120
Y Command - Serial Port Setup	3-121
Z Command - Print Direction	3-122
? Command - Download Variables	3-123
^@ Command - Reset Printer	3-124
^default Command - Set Printer to Factory Defaults	3-125
^ee Command - Error Report - Immediate	3-126
; Command - Code Comment Line	3-127

Appendix A - Character References	A-1
Resident Fonts 1-5	A-1
Default Character Map Code Page - 437	A-2
Euro Character	A-2
Dump Mode Character Map	A-3

Appendix B - Cash Drawer Kicker Option	B-1
Introduction	B-1
Cash Drawer Cable Wiring	B-2
<Esc>p Command - Generate Pulse CDK	B-3
<Esc>u Command - CDK Status	B-4

Introduction

This section contains information about the basic features, command syntax and terminology of the EPL2 Programming Language for Zebra's desktop printers with flash memory architecture. These printers incorporate common programming code sets and architectural features.

The primary operating mode for the printer is EPL2, a page description language. It is designed to assemble all the elements of the label prior to printing to speed the printing process. EPL2 is an ideal language for your labeling and bar code requirements. The EPL2 is versatile and is capable of printing a wide range media and bar codes.

Some printer models also include a legacy printer compatibility mode, Line Mode. Line Mode supports our early model EPL programming language - ELP1. A separate manual is provided for Line Mode printing (p/n 980353-001). See the printer's Software and Documentation CD with the specific model's Programmer's Manual button selector or visit our web site at: www.zebra.com

Command Conventions The manual uses the following typographic conventions to describe commands.

Example	Description										
A	Commands (Case Sensitive)										
p_1, p_2, p_3	Required parameters										
[p_1, p_2, p_3]	Optional parameters										
{Choice 1 Choice 2}	Indicates a mandatory choice between two or more items. You must include one of the items unless all of the items are also enclosed in square brackets.										
This text should be on one line →	The line-continuation character (→) indicates that code is continued from one line to the next and should be typed all on one line.										
↵	Line feed character.										
"NAME"	The name of a form or graphic in double quote marks.										
"DATA"	The text or bar code data in double quote marks. The (\) character designates that the character following is a literal and will encode into the data field. Refer to the following examples:										
	<table border="0" style="margin-left: 20px;"> <thead> <tr> <th style="text-align: left;">To Print</th> <th style="text-align: left;">Enter into Data Field</th> </tr> </thead> <tbody> <tr> <td>"</td> <td>\"</td> </tr> <tr> <td>"Company"</td> <td>\ "Company\"</td> </tr> <tr> <td>\</td> <td>\\</td> </tr> <tr> <td>\code\</td> <td>\\code\\</td> </tr> </tbody> </table>	To Print	Enter into Data Field	"	\"	"Company"	\ "Company\"	\	\\	\code\	\\code\\
To Print	Enter into Data Field										
"	\"										
"Company"	\ "Company\"										
\	\\										
\code\	\\code\\										
"PROMPT"	An ASCII text field that will be transmitted to the host (via the serial interface) each time this command is executed.										



Attention!!

All commands and alpha character command parameters are case sensitive!

Basic Command Syntax Each command consists of one or two ASCII (case sensitive) alpha characters to identify the specific command desired. Some commands require one or more additional parameters to supply the printer with sufficient information to complete the command. Refer to Figure 1- for the basic command syntax.

Figure 1-1
Basic Command
Syntax

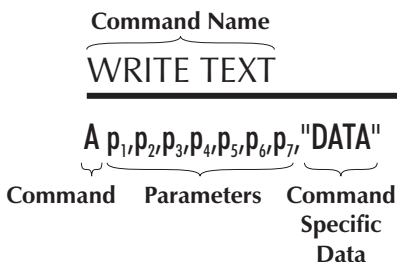

Each command line must be terminated with a Line Feed (**LF**) character (Dec. 10). Most PC based systems send **CR/LF** when the Enter key is pressed. The Carriage Return (**CR**) character is ignored by the printer and cannot be used in place of **LF**.

Command Editor One method to create command files is through an ASCII based text editor. In the DOS environment, MS-DOS EDIT or BRIEF are good choices. In the Windows environment, TextPad® for Windows is a good choice and is available for download of a free evaluation copy at: www.textpad.com

To execute the file, use the editor's print command or from the DOS prompt, use the COPY command to send the file directly to the printer. An example of the use of the COPY command is:

COPY "FILENAME.EXT" LPT1 ↵
or
COPY FILENAME.EXT" COM1 ↵

For more information on the use of the COPY command, refer to your DOS software manual. Configure the COM port to match the printer's serial port setting (typically set to defaults). See the **Y** command in section 2 for details.

Placing Elements in the Print Image

Image elements are located in the image print buffer on a X-Y grid expressed in dots. The X value represents the width and the Y value represents the height of the grid.

The point of origin (the starting point) for a non-rotated object is the upper left corner. As an object rotates, the point of origin rotates with the object.

These image buffer properties are depicted graphically in the following illustration.

Sample Format

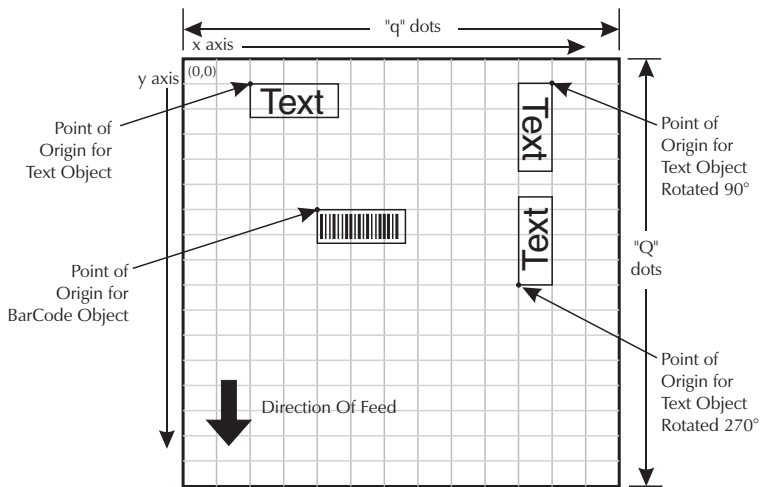

The minimum non printing margin on all edges of the label is 1mm. Printing closer than 1mm to the top or bottom edge of the label may cause the printer to advance unwanted labels or cause the printer to go into error condition.

Text (Fonts) The standard EPL2 printer has five (1-5) resident mono-spaced dot fonts. Fonts A-Z and a-z (upper and lower case alpha characters) are reserved for downloading soft fonts.

— First Character of Text String Reference Point

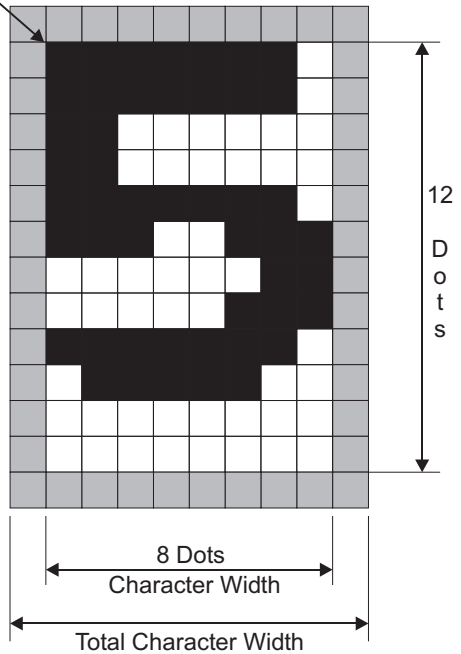

■ = Inter-character Space
(actually white dots)

Control text height (in horizontal dots) and width (in vertical dots) with the horizontal and vertical multipliers. The text is oriented first and then the **A** command's font multipliers are applied.

The text is placed into the image buffer. See the following example.

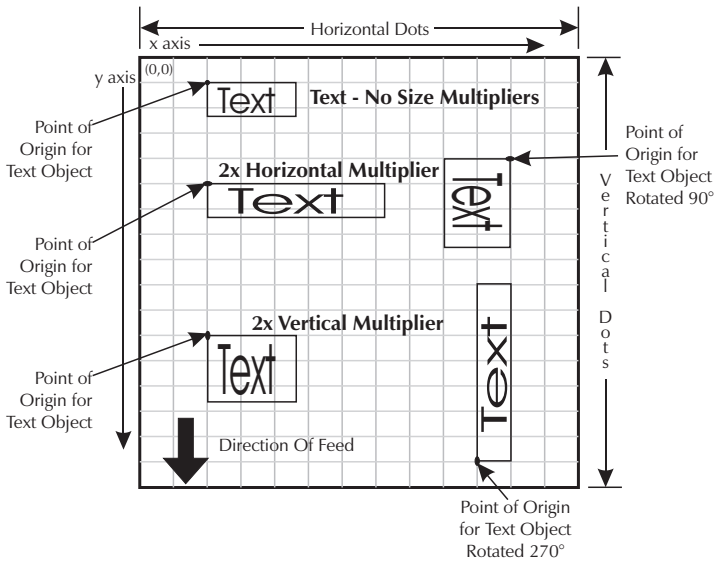

The reference point of the first character in a text string is not affected by the font size multiplier values.

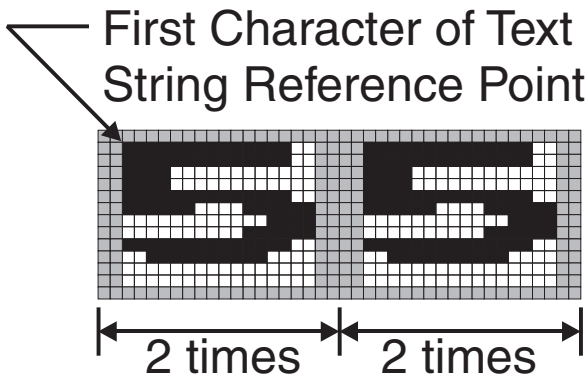

Bar Codes All bar codes supported by the EPL2 language have associated industry specifications that the programmer should be aware of and adhere to. The programmer needs to consider bar code features and requirements when choosing and using a bar code for different applications. Some of the features and requirements that need consideration are listed below:

- ❑ Data used by the application are per the bar code specification (numbers only, alphanumeric, alphanumeric and special characters, etc.).
- ❑ Minimum and maximum number of characters allowed or required per bar code.
- ❑ Density or magnification of a given bar code type.
- ❑ White area required around bar codes (the “Quiet Zone”).
- ❑ The bar code must print within the image buffer (printable area of the label).



Bar Code Orientation Tip

To help ensure that generated bar codes are readable by the widest variety of bar code readers, print bar codes in the “Picket Fence” orientation versus the “Ladder” orientation.

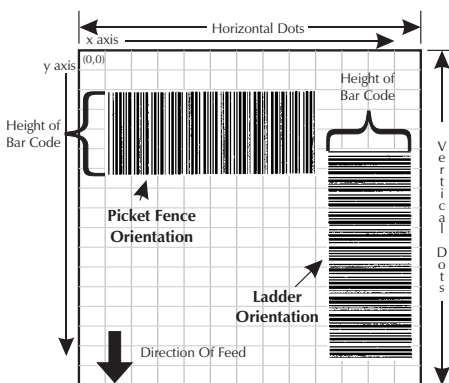

***Programming
Sequences Affect
Graphic Results***

Graphic elements can interact and the resultant image can be affected by other commands. Structure command sequences to reduce the chances of unexpected print results. The printer will process lines, text, boxes and most bar codes in command sequence. The printer then processes the printer control processes, counters, variable data, Postnet, and then graphics last.

Printer Configuration

This section covers the interpret your printer's configuration setup and setting basic modes.

Printer AutoSense Feature Use the printer's AutoSense feature to determine your printer's configuration and operating mode. The primary functions that AutoSense provides are:

- ❑ Adjustment of the Media Sensor in the printer to the media in use.
- ❑ Programming Mode - Page (EPL2) or Line (EPL1 emulation) Mode. Note - Line Mode is not available for all printer models.
- ❑ The printer' serial interface settings.
- ❑ Reports the printer's configuration status including printer options.

Explanation of the Status Printout

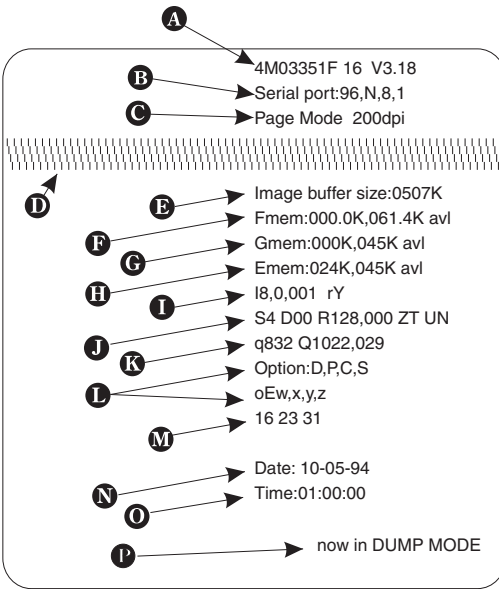

Dump Mode Print Sample

- A. Printer I.D. code number and firmware version number.
- B. Serial port configuration.
- C. Programming Mode
- D. Print head resolution
- E. USB is printed here if installed
- F. Amount of memory available for the Image buffer.
- G. Amount of memory used and memory available for Form storage.
- H. Amount of memory used and memory available for Graphics storage.
- I. Amount of memory used and memory available for Soft fonts.
- J. Currently selected Character Set (**I**) and Image Buffer mode setting (**r**).
rY = Double Buffering Enabled
rN = Double Buffering Disabled
- K. Currently selected Print Speed (**S**), Heat Density (**D**), Reference Point (**Z**), Print Orientation (**Z**) and Error Status (**U**).
- L. Currently selected Form Width (**q**) and Length (**Q**).
- M. Current Hardware and Software Option status .
- N. Current AutoSense Through (Gap) Sensor values. The three numbers represent;
1. Backing Transparent point
2. Set point
3. Label Transparent point.
- O. Current time set in Real Time Clock. This value will only be displayed if your printer is equipped with the Real Time Clock feature.
- P. Current date set in Real Time Clock. This value will only be displayed if your printer is equipped with the Real Time Clock feature.
- P. Current Dump Mode Status.

Determining Printer Firmware Version

The printer version numbers are a code used to document product function and the feature support level of the printer. The latest firmware version and updates can be obtained from our web site.

Programming Mode Configuration

Flash based printers are, by default, configured for Page (EPL2) mode operations. The operator must convert the printer to Line Mode prior to the initial use of Line Mode. This is done via a hardware select procedure with the Feed button during printer power-up. See the **OEPL1** command (page 3-86) for details on switching between line and page modes via programming.

As of January 2001, the following printers support Line Mode (EPL1 emulation):

- LP2443
- LP2722
- LP2824 & TLP2824
- LP2844



The Line Mode (and Page Mode) configuration setting is retained after reset has been issued or power has been cycled.

Manually Setting Line Mode

The Line Mode capable printer utilizes the Feed button during printer power-up to toggle between the printer personality modes, Line and Page (EPL2).

1. With printer power off, press and hold the Feed button while turning the printer on, then release the button when the LED starts blinking red.
2. When the indicator LED starts flashing green, immediately press and hold Feed button.
3. Release the Feed button when the LED turns a steady Amber (orange).
4. Verify printer personality with Dump Mode printout:.. Line Mode or Page Mode (EPL2).
5. Press the Feed button to exit the Dump Mode.

Media Detection Media detection in EPL2 printers is a combination of programming and printer media sensing. The **Q** (Set Form Length) and **O** (Option) commands program the media detection method. The user must configure the printer for the media type and the (programmed) form or label in use.

The printer can detect the beginning and end of the printable area on the media by one of three methods: Gap, Notch (hole), or Black line. The Gap method detects the difference in optical density of a label on a liner from the liner only with the Transmissive (Gap) sensor. The Notch method uses the Transmissive sensor to detect a hole in the media (gap-less labels or tag stock). The Black line method uses the Reflective sensor to detect a preprinted black line on the media back (for gap-less labels or tag stock).

Printing on continuous media requires programming to control media positioning.

EPL2 printers also support a “Label Dispense” mode as a printer configuration option (for most models). The printers use a “Label Taken” sensor to detect the removal of a label.

One or more of these sensors may require user adjustment or configuration for proper operation. All EPL2 printers have an AutoSense feature to optimize label and label gap detection by the transmissive (gap) sensor. See the printer’s user’s manual for printer specific sensor adjustment control.

Command Reference

This section contains a complete listing of all commands in alphabetical order.

Command	Description	Memory ‡	Page
A	ASCII Text		3-4
AUTOFR	Automatic Form Printing		3-9
B	Bar Code		3-11
B	RSS-14 Bar Code		3-16
b	Data Matrix		3-20
	MaxiCode		3-25
	PDF417		3-29
C	Counter		3-37
C	Cut Immediate		3-39
D	Density	Stored	3-40
EI	Print Soft Font Info.		3-43
EK	Delete Soft Font	Writes	3-44
eR	User Definable Error Response	Writes	3-42
ES	Store Soft Font	Writes	3-45
f	Cut/Peel Position	Stored	3-50
FE	End Form Store	Writes	3-51
FI	Print Form Info.		3-52
FK	Delete Form	Writes	3-53
FR	Retrieve Form		3-54
FS	Store Form	Writes	3-55
GG	Retrieve Graphics		3-57
GI	Print Graphics Info.		3-58
GK	Delete Graphic	Writes	3-59
GM	Store Graphic	Writes	3-60
GW	Direct Graphic Write		3-62
I	Character Set Selection	Stored	3-63
JB	Disable Top Of Form Backup	Stored	3-65
JC	Disable Top Of Form Backup - All Cases	Stored	3-66
JF	Enable Top Of Form Backup	Stored	3-67
LE	Line Draw Exclusive OR		3-68
LO	Line Draw Black		3-69
LS	Line Draw Diagonal		3-70
LW	Line Draw White		3-71
M	Memory Allocation	Writes	3-72
N	Clear Image Buffer		3-73
o	Cancel Customized Settings	Writes	3-74
oB	Cancel Customize Bar Code	Writes	3-75
oE	Line Mode Font Substitution	Writes	3-76
oH	Macro PDF Offset		3-77
oM	Disable Initial Esc Sequence Feed	Stored	3-79
oR	Character Substitution (Euro)	Writes	3-80
oW	Customize Bar Code Parameters	Writes	3-82

Command	Description	Memory ‡	Page
O	Options Select	Stored	3-84
OEPL1	Set Line Mode	Writes	3-86
P	Print		3-87
PA	Print Automatic		3-88
Q	Set Form Length Transmissive (Gap) Sensor Black Line Sensor Continuous Stock	Stored	3-91
q	Set Form Width	Stored	3-89
r	Set Double Buffer Mode	Stored	3-95
R	Set Reference Point	Stored	3-96
S	Speed Select	Stored	3-97
TD	Define Date Layout (& Print Date)		3-98
TS	Set Real Time Clock		3-99
TT	Define Time Layout (& Print Time)		3-100
U	Print Configuration		3-101
UA	Enable Clear Label Counter Mode		3-102
UB	Reset Label Counter Mode		3-103
UE	External Font Information Inquiry		3-104
UF	Form Information Inquiry		3-105
UG	Graphic Information Inquiry		3-106
UI	Host Prompts/Codepage Inquiry		3-107
UM	Codepage & Memory Inquiry		3-108
UN	Disable Error Reporting	Stored	3-109
UP	Codepage & Memory Inquiry/Print		3-110
UQ	Configuration Inquiry		3-111
US	Enable Error Reporting	Stored	3-112
V	Define Variable		3-116
U%	Host Prompts/Battery Inquiry		3-114
U%	Host Prompts/Motor Temperature Inquiry		3-115
W	Windows Mode	Stored	3-118
xa	Sense Media	Writes	3-119
X	Box Draw		3-120
Y	Serial Port Setup	Stored	3-121
Z	Print Direction	Stored	3-122
?	Download Variables		3-123
^@	Reset Printer		3-124
^default	Set Printer to Factory Defaults	Writes	3-125
^ee	Status Report - Immediate		3-126

‡ - Stored memory commands will check for differences with the existing command setting prior to validating a memory write operation. The printer's non-volatile "flash" memory has a limited number of write cycles (100,000 plus).

A Command - ASCII Text

Description Prints an ASCII text string.

Syntax **A****p**₁,**p**₂,**p**₃,**p**₄,**p**₅,**p**₆,**p**₇,**"DATA"**

Parameters **p**₁ = Horizontal start position (X) in dots.

p₂ = Vertical start position (Y) in dots.

p₃ = Rotation

Value	Description
0	No rotation
1	90 degrees
2	180 degrees
3	270 degrees

p₄ = Font selection

Value	Description	
	203 dpi	300 dpi
1	20.3 cpi, 6 pts, (8 x 12 dots)	25 cpi, 4 pts, (12 x 20 dots)
2	16.9 cpi, 7 pts, (10 x 16 dots)	18.75 cpi, 6 pts, (16 x 28 dots)
3	14.5 cpi, 10 pts, (12 x 20 dots)	15 cpi, 8 pts, (20 x 36 dots)
4	12.7 cpi, 12 pts, (14 x 24 dots)	12.5 cpi, 10 pts, (24 x 44 dots)
5	5.6 cpi, 24 pts, (32 x 48 dots)	6.25 cpi, 21 pts, (48 x 80 dots)
A - Z	Reserved for Soft Fonts	Reserved for Soft Fonts
Fonts 1 - 5 are fixed pitch.		

p₅ = Horizontal multiplier, expands the text horizontally. Values: 1, 2, 3, 4, 5, 6, & 8.

p₆ = Vertical multiplier, expands the text vertically. Values: 1, 2, 3, 4, 5, 6, 7, 8, & 9.

p₇ = **N** for normal or **R** for reverse image

"DATA" = Represents a fixed data field.

A Command - ASCII Text

The backslash (\) character designates the following character is a literal and will encode into the data field. Refer to the following examples:

<u>To Print</u>	<u>Enter into data field</u>
“	\”
“Company”	\”Company\”
\	\\
\code\	\\code\\

Examples: ↵
N↵
A50,0,0,1,1,1,N,"Example 1"↵
A50,50,0,2,1,1,N,"Example 2"↵
A50,100,0,3,1,1,N,"Example 3"↵
A50,150,0,4,1,1,N,"Example 4"↵
A50,200,0,5,1,1,N,"EXAMPLE 5"↵
A50,300,0,3,2,2,R,"Example 6"↵
P1↵

Will Produce:

Example 1

Example 2

Example 3

Example 4

EXAMPLE 5

Example 6



As shown in example 5 above, font 5 only supports upper case characters. Refer to Appendix A for a complete listing of available fonts and character sets supported.



Use the **LE** command to create reverse print text instead of the “**R**” in the **A** command parameter **p7**. This is the recommend method because it provides the best size, position and centering of the black line (rectangle) bordering the reversed text.

A Command - ASCII Text

Variable Data and Counter Functions The “**Data**” field can be replaced by or combined with the following commands:

Vnn= Prints the contents of variable “**nn**” at this position where **nn** is a 2 digit number from 00 to 99. See the **V** command, page 3-116

Cn= Prints the contents of counter “**n**” at this position where **n** is a one digit number from 0 to 9. See the **C** command, page 3-37.

Example: A50,0,0,1,1,1,N,"DATA"␣ : Writes Text
A50,50,0,2,1,1,N,V01␣ : Writes contents of variable 01
A50,100,0,3,1,1,N,C1␣ : Writes contents of counter 1
A50,100,0,3,1,1,N,C1+2␣ : Writes contents of counter 1 plus 2

Data with the RTC Time & Date Functions The “**Data**” field can be replaced by or combined with the following variables:

TT = Prints the current time at this position in the predefined format. See the **TT** command for format selection. This variable is available only if the printer Time & Date option is installed.

TD = Prints the current date at this position in the predefined format. See the **TD** command for format selection. This variable is available only if the printer Time & Date option is installed.

Examples: A50,150,0,4,1,1,N,TT␣ : Writes current time
A50,200,0,5,1,1,N,TD␣ : Writes current date

or a combination of several options:

A50,300,0,3,2,2,R,"Deluxe"V01C2"Combo"TDV01TT␣

:Writes the text “Deluxe” followed by the contents of variable 01 followed by the contents of counter 2 followed by the text “Combo” followed by the current date followed by the contents of variable 01 followed by the current time.

A Command - ASCII TEXT

Simple Expressions in Data Fields An advanced function of the **A** command allows addition and subtraction to be performed on constant and variable values in flash printers.

Syntax **A***p*₁,*p*₂,*p*₃,*p*₄,*p*₅,*p*₆,*p*₇, "DATA"[*p*₈*p*₉*p*₁₀...]

Parameters For the *p*₁ - *p*₇ and "DATA" parameters -
See first page of **A** command, page 3-4.

p₈ = Required. Must be a variable data field number, e.g. V00, V01 etc.

p₉ = Required. Operator, + or -

p₁₀ = Required. Variable data field number or constant value.

Valid Number Ranges:

Constant = 0 to 2147483647

Variable = 0 to 2147483647

Result = -2147483648 to 2147483647

- The Expression must start with a variable field.
- The character field length defined for the first variable in the expression will be used to format the result. If the result is of a greater length than the defined character length, then the result field will contain 'X's.
- A syntax error will be generated during form storage if the constant value is too large.
- If an error occurs during the evaluation of the expression, the resultant field will be filled with 'X's.

A Command - Simple Expressions in Data Fields

Example:

```
FK"1"
FK"1"
FS"1"
V00,10,N,"Enter current mileage."
A100,100,0,4,1,1,N,"Current mileage is "V00" miles."
A100,200,0,4,1,1,N,"Change oil at "V00+3000" miles."
FE
FK"2"
FK"2"
FS"2"
V00,10,N,"Enter current mileage."
V01,10,N,"Enter interval mileage."
A100,100,0,4,1,1,N,"Current mileage is "V00" miles."
A100,200,0,4,1,1,N,"Mileage interval is "V01" miles."
A100,200,0,4,1,1,N,"Change oil at "V00+V01" miles."
FE
FK"3"
FK"3"
FS"3"
V00,10,N,"Enter value 1."
V01,10,N,"Enter value 2."
V02,10,N,"Enter value 3."
A100,200,0,4,1,1,N,"Answer: "V01+123+V00-10-V02"
```

Asian Character Font Sets The flash based printers support up to five Asian language character (ideogram) sets. Asian language support is an optional feature and requires a special version of the printer (PCBA) to support the large Asian character sets.

The Asian character maps and special features of the **A** command that support the character sets can be found in a separate publication or on our Asian Desktop printer CD ROM.

For Asian language firmware updates, publications and support options see:

www.zebra.com

AUTOFR Command - Automatic Form Printing

Description This special form process allows you to detach the printer from the computer and print in a standalone mode. The EPL2 printer reserves the form name **AUTOFR** to allow the printer to automatically start a form when the printer is initialized power-up. This feature can be used in many ways, that include the following:

- Feed a single label in peel mode and print multiple labels set to the number of labels on the roll.
- Have a form with a variable and enter the variable with a scanner, terminal, weight scale, circuit analyzer or any other device capable of sending ASCII character data.

Mobile printers, such as the TR 220, ignore this command.

Using AUTOFR Download a form to the printer with the name **AUTOFR**.

Example:

↵	:Line Feed to initialize the printer
FK"AUTOFR"↵	:Form Kill (delete any existing AUTOFR)
FS"AUTOFR"↵	:Form Save (save file from here to FE at the bottom)
V00,8,L,""↵	:Variable field definition
Q254,20↵	:Label height followed by gap width
S2↵	:Speed (2ips)
D7↵	:Density setting
ZB↵	:Print direction (ZT flips it 180 degrees)
A340,20,0,4,1,2,N,"QUANTITY"↵	:Fixed text line
B265,75,0,3,2,4,101,B,V00↵	:Bar code definition
PA1↵	:Print 1 label Automatically *
FE↵	:Form End (Line Feed)

* - If using the CAL TOOLS, CAL WIN, etc. programs to generate label files (files with .ejf extensions), then the **PA** command must be added manually by editing the .ejf file.

AUTOFR - Automatic Form Printing Feature



AUTOFR treats any incoming data as a variable intended for printing. This means if you send the printer a memory partition command, the label will print, if you send a delete command - the label will print! So, while you are testing **AUTOFR** it is best to use another name for the form. Once you are satisfied with the form, rename it **AUTOFR** before you download it. There is no need to specify a file extension.

Isolating Data From the Input Device Place the printer in the diagnostic dump mode and send from your data input device.

- All characters the device sends will be printed on the label.
- If nothing prints, nothing is arriving - check pin-outs and serial settings.

Disabling AUTOFR Send a XOFF data character (13 hex. or ASCII 19) or a NUL (00 hex. or ASCII 0) to the printer.

The form may now be deleted from the printer.

Removing AUTOFR The programmer must send a Delete Form - **FK** command to the printer after disabling **AUTOFR**.

Example: FK"AUTOFR"↵
FK"AUTOFR"↵

B Command - Bar Code

Description Use this command to print standard bar codes.

Syntax **B****p**₁,**p**₂,**p**₃,**p**₄,**p**₅,**p**₆,**p**₇,**p**₈,**"DATA"**

Parameters **p**₁ = Horizontal start position (X) in dots

p₂ = Vertical start position (Y) in dots.

p₃ = Rotation

Value	Description
0	No rotation
1	90 degrees
2	180 degrees
3	270 degrees

p₄ = Bar Code selection (see Table 2-1 on next page).

p₅ = Narrow bar width in dots. (see Table 2-1 on next page).

p₆ = Wide bar width in dots.
Acceptable values are 2-30.

p₇ = Bar code height in dots.

p₈ = Print human readable code.
Values: **B**=yes or **N**=no.

"DATA" = Represents a fixed data field. The data in this field must comply with the selected bar code's specified format.

The backslash (\) character designates the following character is a literal and will encode into the data field. Refer to the following examples:

<u>To Print</u>	<u>Enter into data field</u>
"	\"
"Company"	\\"Company\"
\	\\
\code\	\\code\\

B Command - Bar Code

Bar Codes

Description	P ₄ Value	P ₅ Value
Code 39 std. or extended	3	1-10
Code 39 with check digit	3C	1-10
Code 93	9	1-10
Code 128 UCC Serial Shipping Container Code	0	1-10
Code 128 auto A, B, C modes	1	1-10
Code 128 mode A	1A	1-10
Code 128 mode B	1B	1-10
Code 128 mode C	1C	1-10
Codabar	K	1-10
EAN8	E80	2-4
EAN8 2 digit add-on	E82	2-4
EAN8 5 digit add-on	E85	2-4
EAN13	E30	2-4
EAN13 2 digit add-on	E32	2-4
EAN13 5 digit add-on	E35	2-4
German Post Code	2G	3-4
Interleaved 2 of 5	2	1-10
Interleaved 2 of 5 with mod 10 check digit	2C	1-10
Interleaved 2 of 5 with human readable check digit	2D	1-10
Postnet 5, 9, 11 & 13 digit ¹	P	—
Planet 11 & 13 digit ¹	PL	
Japanese Postnet	J	—
UCC/EAN 128 ²	1E	1-10
UPC A	UA0	2-4
UPC A 2 digit add-on	UA2	2-4
UPC A 5 digit add-on	UA5	2-4
UPC E	UE0	2-4
UPC E 2 digit add-on	UE2	2-4
UPC E 5 digit add-on	UE5	2-4
UPC Interleaved 2 of 5	2U	1-10
Plessey (MSI-1) with mod. 10 check digit	L	—
MSI-3 with mod. 10 check digit	M	—

1. Hyphens maybe used in data, as a data separator and will be ignored.

2. Use ASCII 06 to delimit variable length fields.

B Command - Bar Code

Example: ↵
N↵
B10,10,0,3,3,7,200,B,"998152-001"↵
P1↵

Will Produce:

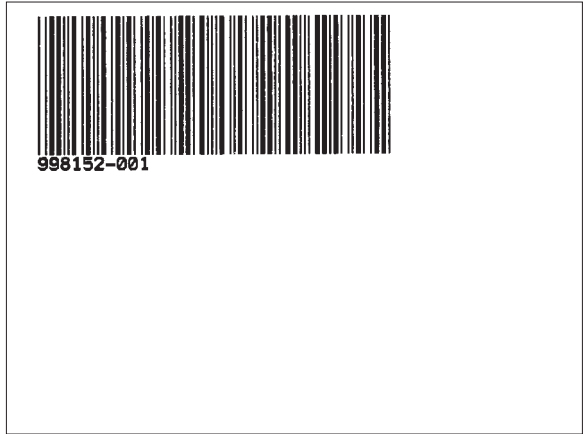

Bar Codes with Variables & Counters

The data field can be replaced by or combined with the following commands:

Vnn = Prints the contents of variable “**nn**” at this position. Range of **nn** = 00 to 99.

Cn = Prints the contents of counter “**n**” at this position. Range of **n** = 0 to 9

See Appendix C for additional **Data** parameters for printers with the RTC (real time clock) option installed.

Examples: B50,0,0,3,1,2,50,B,"DATA"↵ : Writes bar code
B50,50,0,3,1,2,50,N,V01↵ : Writes contents of variable 01 as bar code
B50,50,0,3,1,2,50,N,C1↵ : Writes contents of counter 1 as bar code
B50,50,0,3,1,2,50,N,C1+2↵ : Writes contents of counter 1 plus2 as bar code

or a combination of several options:

B50,300,0,3,1,2,50,B,"Deluxe"V01C2"Combo"V01↵
:Writes the text “Deluxe” followed by the contents of variable 01 followed by the contents of counter 2 followed by the text “Combo” followed by the contents of variable 01 all as a code 39 bar code.

B Command - Bar Code

Data with the RTC Time & Date Functions The “**Data**” field can be replaced by or combined with the following variables:

TT = Prints the current time at this position in the predefined format. See the **TT** command for format selection. This variable is available only if the printer Time & Date option is installed.

TD = Prints the current date at this position in the predefined format. See the **TD** command for format selection. This variable is available only if the printer Time & Date option is installed.



Some bar code formats will not support date names or the date or time delimiters used by the printer to separate data parameters.

Code 128 Bar Code Function Characters The printer supports code 128 function control characters (**FCN#**). Multiple **FCN#**s, **TT**s, **TD**s and “**DATA**” strings can be concatenated, allowing them to be inserted anywhere within the symbol.

FCN2, FCN3 and FCN4 are illegal in code 128 mode C ($p_4 = 1C$) and will result in a syntax error.

Please refer to the Code 128 standard for a description of function characters **FNC1** through **FNC3**.

“Standard” Code 128 can encode all 128 standard ASCII characters (0-127). Function character **FCN4** provides a means of also encoding extended ASCII characters (128-255). It directs the reader to add 128 to the value of each affected character before transmitting it.

Two consecutive **FCN4**s toggle between standard and extended ASCII mode for all succeeding data characters (until the end of the symbol, or until another pair of s is encountered). This is referred to as latching into extended ASCII mode or latching into standard ASCII mode.

B Command - Bar Code

Code 128 Bar Code Function Characters (continued)

A single **FCN4** toggles between standard and extended ASCII mode for only a single following data character. This is referred to as shifting into extended ASCII mode or shifting into standard ASCII mode.

Both code sets A and B are needed to represent the entire extended ASCII character set, just as both sets are needed to represent the standard ASCII character set.

FCN4s can be inserted manually, if necessary or desired, by following the syntax described above. The printer will, however, insert them automatically if extended ASCII characters are encountered in the DATA. It will do so in the most efficient manner possible:

- If up to 4 contiguous extended ASCII characters are encountered, it will shift into extended ASCII mode by inserting a single **FCN4** before each one;
- If 5 or more contiguous extended ASCII characters are encountered, it will latch into extended ASCII mode by inserting two **FCN4s** before them.
- While latched into extended ASCII mode, it will apply the same rules if standard ASCII characters are encountered.

Thus, the preferred way to encode extended ASCII characters is to simply embed them in the DATA and let the printer manage the encoding task. For best results, the code set should also not be specified (i.e., $p4 = 1$). **FCN4s** should be manually inserted only in systems where extended ASCII characters cannot be transmitted to the printer.



It is illegal to mix automatic and manual modes within the data for a single symbol; i.e., an extended ASCII character encountered in the data after an will be considered a syntax error. Likewise, an **FCN4** after an extended ASCII character will also be considered a syntax error.

B Command - RSS-14 Bar Code Specific Options

Description Use this command to print RSS-14 bar code family bar codes for numeric data. The printer supports a subset of the RSS bar code family set. The subset includes basic RSS-14, RSS Limited, RSS Stacked and RSS Truncated. The printer does not support RSS Extended or two dimensional composite bar codes.

Printer Models: 3842

Syntax **B****p₁**,**p₂**,**p₃**,**p₄**,**p₅**,**p₆**,**p₇**,**p₈**,**"DATA"**

Parameters **p₁** = Horizontal start position (X) in dots

p₂ = Vertical start position (Y) in dots.

p₃ = Rotation

Value	Description
0	No rotation
1	90 degrees
2	180 degrees
3	270 degrees

p₄ = RSS-14 Bar Code selection.

Value	Description	Width Multiplier	Min. Height Multiplier
R14	Basic RSS-14	96	33
RL	Limited	50	13
RS	Stacked	96	13
RT	Truncated	74	10

p₅ = Narrow bar width in dots.
The narrowest module will be this number of dots. **Range: 1-10.**

Symbol Width is the value of **p₅** times the applicable bar code **Width Multiplier** listed in the table for the selected RSS-14 bar code type (**p₄**). This overall symbol width value includes the required symbol "quite zone".

p₆ = Required Value is **2**

B Command - RSS-14 Bar Code Specific Options

p7 = Bar code height in dots. See the table above for the Minimum Height Multiplier. The printer will automatically select the larger of two values: **1**) this value and **2**) the Selected narrow bar width (**p5**) times the **Min. Height Multiplier** listed in the table for the selected RSS-14 bar code type (**p4**).

p8 = Print human readable code.
Values: **B**=yes or **N**=no.

“DATA” = Represents a fixed data field of numeric data, **0-9** only.
The printer's data parser will allow the use of leading zeros (0's) or spaces which will be discarded when data is encoded in the bar code.

Value (P4)	Description	Max. Numeric Value
R14	Basic RSS-14	99999999999999
RL	Limited	99999999999999
RS	Stacked	99999999999999
RT	Truncated	19999999999999

Data with the RTC Time & Date Functions The **“Data”** field can be replaced by or combined with the following variables:

TT = Prints the current time at this position in the predefined format. See the **TT** command for format selection. This variable is available only if the printer RTC Time & Date option is installed.

TD = Prints the current date at this position in the predefined format. See the **TD** command for format selection. This variable is available only if the printer RTC Time & Date option is installed.

Because the RSS-14 bar code symbols only support numeric data, the time and date data recalled by the **TD** and **TT** commands must not include delimiters, i.e. **/**, **-**, or **:** or any other delimiters that may be set.

B Command - RSS-14 Bar Code Specific Options

Example #1 N ↴

B100,100,0,RL,4,4,40,B,"1234567890" ↴

B100,300,0,R14,4,4,40,B,"1234567890" ↴

B100,500,0,RS,4,4,52,B,"1234567890" ↴

B100,700,0,RL,4,4,40,B,"9876543210" ↴

P ↴

Will Produce



(01)00012345678905



(01)00012345678905



(01)00012345678905



(01)00098765432105

B Command - RSS-14 Bar Code Specific Options

Example #2 N↵

B100,100,0,RL,4,4,40,B,"1234567890"↵
B400,300,0,RT,4,4,40,B,"1234567890"↵
B500,900,0,RS,4,4,54,B,"1234567890"↵
B500,900,1,RS,4,4,54,B,"1234567890"↵
B500,900,2,RS,4,4,54,B,"1234567890"↵
B500,900,3,RS,4,4,54,B,"1234567890"↵
B100,1350,0,RL,4,4,40,B,"9876543210"↵
P↵

Will Produce

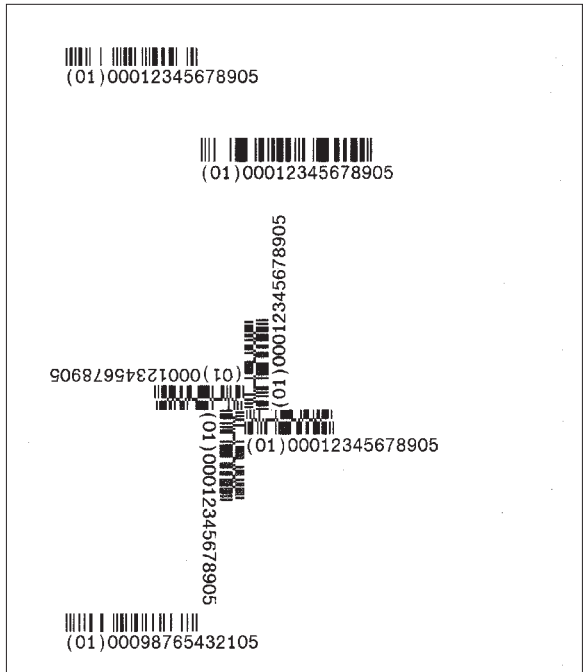

b Command - 2D Bar Code - Data Matrix Specific Options

Description Use this command to print Data Matrix two dimensional bar code symbols. The printer will automatically interpret and encode data into Data Matrix bar code symbols, using the ECC 200 data quality format. Individual module size, columns and rows parameters can be specified or the printer can automatically calculate and set one or all of these parameters.

The symbol is made of square modules arranged within a rectangular shape which includes a perimeter scan recognition pattern. The scan recognition pattern produced by the EPL2 printer also includes a "quiet zone" one module wide on all outside edges of the bar code to ensure data integrity.

Printer Models: 3842

Syntax **bp₁,p₂,p₃,[p₄],[p₅][p₆][p₇],"DATA"**

Parameters The printer will automatically generate the Data Matrix bar code using the following parameters.

p₁ = Horizontal start position (X) in dots.

p₂ = Vertical start position (Y) in dots.

p₃ = **D** - Selects Data Matrix bar codes

Order is not important for parameters **p₄-p₇**
Include the prefix letter (**c**,**r**,**h**, or **v**) to select the parameter followed by a valid numeric value.

p₄ (c) = Number of columns to encode
See the Symbol Geometries table for valid column values.

p₅ (r) = Number of rows to encode
See the Symbol Geometries table for valid row values.

p₆ (h) = Sets the minimum square data module size used for encoding data.
Range: 1-40 Default: 5

p₇ (v) = Selects an inverse image of the bar code (sometimes known as reverse video or a negative image).

b Command - 2D Bar Code - Data Matrix Specific Options

“DATA” = ASCII data or Binary data bytes

Any combination of data strings, time fields (**TT**), date fields (**TD**), variables and/or counters (the latter two within forms only) that resolve to a valid string of characters.

Within literal strings all ASCII characters 0–255 dec. (00-FF hex.) are allowed. Quotes (ASCII 34d) and backslashes (ASCII 92d) must be uniquely handled.

The backslash (\) character designates the following character is a literal and will encode into the data field. Refer to the following examples:

<u>To Print</u>	<u>Enter into data field</u>
“	\"
“Company”	\"Company\"
\	\\
\code\	\\code\\
↵	↵

Within forms, further limitations include that a NULL (ASCII 0) character may not appear within bar code DATA and entry limitations do not provide for a way to enter linefeed characters into variables.

The programmer should rely on the symbology’s specification to insure format compliance and proper implementation. See the AIM web site for specifications at:

<http://www.aimi.org/>

b Command - 2D Bar Code - Data Matrix Specific Options

Data Matrix Symbol Geometries

Rows	Columns	Numeric Capacity¹	Alpha-numeric Capacity²	Compressed data size³
8	18	10	6	5
8	32	20	13	10
10	10	6	3	3
12	12	10	6	5
12	26	32	22	16
12	36	44	31	22
14	14	16	10	8
16	16	24	16	12
16	36	64	46	32
16	48	98	72	49
18	18	36	25	18
20	20	44	31	22
22	22	60	43	30
24	24	72	52	36
26	26	88	64	44
32	32	124	91	62
36	36	172	127	86
40	40	228	169	114
44	44	288	214	144
48	48	348	259	174
52	52	408	304	204
64	64	560	418	280
72	72	736	550	368
80	80	912	682	456
88	88	1152	862	576
96	96	1392	1042	696
104	104	1632	1222	816
120	120	2100	1573	1050
132	132	2608	1954	1304
144	144	3116	2335	1558

1. Paired digits represents the best-case compression. Adjacent digit pairs can be encoded into eight bits.

2. The implied compressibility requires the data be composed of either all lowercase or all uppercase characters with digits and spaces allowed.

3. Any ASCII character (0-127) can be encoded one-to-one, extended ASCII (128-255) requires an additional two-byte overhead.

b Command - 2D Bar Code - Data Matrix Specific Options

Automatic Data Matrix Bar Code Generation The printer automatically tests and changes the Data Matrix bar code geometry to optimize the symbol size per the specified column and row (**p₄** - the **c** prefix and **p₅** - the **r** prefix) parameters. If no *row* or *column* parameters are specified, the printer will create a minimum size symbol based on the calculated **compressed size** of the *data*. The number of columns and rows in the symbol will be automatically determined with a preference towards the smallest **square** symbol that will accommodate the **compressed size**.

The user may wish to force the number of rows and/or columns to a larger value to achieve uniform symbol sizes.

If the column (**c**) parameter is only specified and it's "18", "26", "32", "36", or "48", or if only *rows* is specified and it is "8", "12", or "16", a rectangular symbol may be produced. For example, if ",r12" is specified (with no *column* parameter), then sizes 12x12, 12x26, and 12x36 are possible selections. The alphanumeric capacity of those symbols is 6, 22, or 31 characters respectively. The smallest symbol size that will accommodate the data will be created. If *rows*, *cols*, and/or *data* length are not compatible with a symbol from the Symbol Geometries table, an error 03 (Data Length Error) will be reported, and no symbol will be produced.

b Command - 2D Bar Code - Data Matrix Specific Options

Example: N↵

b30,20,D,h8,"Zebra Technologies corporation is the leading worldwide manufacturer of bar code labeling solutions and a leading provider of instant-issuance plastic card printers. We distribute our on-demand bar code label printers, plastic card printers, secure ID printing systems, software and related supplies under the Zebra and Eltron brand names to users in more than 90 countries. Our products are used in high-growth automatic identification applications that improve quality and productivity. We count among our customers more than 70 percent of the FORTUNE 500."↵

Will Produce:



b Command - 2D Bar Code - MaxiCode Specific Options

Description Use this command to generate MaxiCode bar code symbols with a single command. The printer will automatically interpret and encode data into MaxiCode symbols for data modes 2, 3, 4, and 6. Up to eight symbols can be linked.

Syntax **bp₁,p₂,p₃,[p₄,][p₅,]"DATA"**

Parameters **p₁** = Horizontal start position (X) in dots

p₂ = Vertical start position (Y) in dots

p₃ = **M** - Must be "M" for MaxiCode

p₄ = Mode Selection

Value	Description
Not Used	Automatic Selection Mode 2 or 3
M2	Mode 2
M3	Mode 3
m4	Mode 4
m6	Mode 6

1. If **p₄** (**Mx**) is not used, the printer will use the following rules to automatically format the "DATA" parameter. If the postal code (third parameter, PC) in the "DATA" is:

- All numeric characters, the printer will automatically select Mode 2.
- Alpha only or alpha-numeric character combinations will set the printer to Mode 3.
- Not used, the printer automatically selects Mode 3.

2. If **p₄** value is "**M2** or **M3**", the printer will use the following rules to format the "Data" parameter:

- **In Mode 2** - If a non-numeric character is entered in the Postal Code "Data" parameter field, then the MaxiCode bar code will not print.
- **In Mode 3** - If the Postal Code "Data" field exceed 6 characters, then the additional characters will be truncated from the bar code field.

b Command - 2D Bar Code - MaxiCode Specific Options

P5 = **x,y**

Associated MaxiCode symbol numbering where:

x = Symbol Number of

y = Total Number of Associated Symbols

Default: Not used

Range: 1-8 for both **x** or **y**

”DATA” = Mode Dependent Data Format

Mode dependent data is bounded by quotation marks. Maximum of 2 KBytes of data.

Mode	Data Format
2 & 3	“ cl,co,pc,lpm ”
4 & 6	“ lpm ”

cl = **Class Code** (3 digits required)

co = **Country Code** (3 digits required)

Mode 2 = Numeric Characters

Mode 3 = International Characters
(up to 6 characters)

pc = Postal Code

Mode 2 = 5 or 9 characters

(All Numeric, including USA
Postal ZIP 5 or 9 char.)

For less than 9 characters, the
printer will pad the field with 0's.

Mode 3 (International) = Any
alphanumeric character

(up to 6 characters)

lpm = **Low priority message** (data)

ASCII printable characters (up to
84 characters per symbol), any
256 character map.

The programmer should rely on the symbology's specification to insure format compliance and proper implementation. See the AIM web site for specifications at:

<http://www.aimi.org/>

b Command - 2D Bar Code - MaxiCode Specific Options

Example: N↵
b20,20,M,"300,840,93065,1692,This is MaxiCode, but not MaxiCode
formatted data"↵
P1↵

Will Produce:



**Using AIM Specified
MaxiCode Data
Formatting**

The EPL printer can use and automatically de- code the AIM ITS (International Technical Standards) MaxiCode data format. The printer detects the message/start header (**[]>R_S**), field separator (**G_S**), and the end of message marker (**R_S E_{OT}**) data control strings.

The hexadecimal (ASCII) data control strings are in the following table. See the EPL2 dump mode character map in Appendix A.

Control String	Hexadecimal Code
Message/Start Header	
[] > R_S	5B 29 3E 1E
Field Separator	
G_S	1D
End Of Message Marker	
R_S E_{OT}	1E 04

Syntax **bp₁,p₂,M,p₄ “[AIM MaxiCode Data]”**

Example **b20,400,M,m2”001,840,93065,1692,]>R_S
01G_S98XXXXZFDAAFG_SSHIPG_S309G_SG_S1/1G_S10G_S
NG_SG_SCAMARILLOG_SCAG_SR_SE_{OT}!!!!!!!!!!!!!!!!!!!!!!!!!!!!” ↵**

- Notes:
- 1) This programming example represents actual data used to format a single AIM compliant MaxiCode symbol as programmed by a major international and domestic shipping company.
 - 2) The shipper has explicitly set the MaxiCode symbol for Mode 2. This can be omitted by the programmer and the printer will auto-select the mode per the rules on page 3-25.
 - 3) The shipper has used the “!” character to pad the symbol’s data. A scanner reads back all the “Data” within the quotation marks, including the “!” characters following the End Of Message Marker (**E_{OT}**).
 - 4) All of the data fields in the Low Priority Message are not used in the example. Some are left empty with the field delimiting **G_S** character used as a format field holder.

b Command - 2D Bar Code - PDF417 Specific Options

Description Use this command to print PDF 417 and Macro PDF bar code symbols. The printer will automatically change from PDF417 to Macro PDF bar code mode if the data sent to the printer exceeds the maximum amount supported by the PDF417 symbol. The **oH** command is used to place the addition Macro PDF symbols needed for the continuation data.

The printer will automatically optimize the symbol for readability of data (and use the minimum number of symbols when using Macro PDF). The symbol's geometry is adjusted (typically reducing the size of the symbol) per the defined parameters. The printer will use the largest module size (bar width and height) and minimize the number of rows and columns.

Syntax **p₁,p₂,p₃,p₄,p₅[p₆][p₇][p₈][p₉][p₁₀][p₁₁][p₁₂][p₁₃][p₁₄][p₁₅,"DATA"**

Parameters The printer will automatically generate the PDF417 bar code using the following parameters.

p₁ = Horizontal start position (X) in dots

p₂ = Vertical start position (Y) in dots

p₃ = **P** - Must be "P" for PDF 417 bar codes

p₄ (www) = maximum print width in dots

p₅ (hhh) = maximum print height in dots

The programmer should rely on the symbology's specification to insure format compliance and proper implementation. See the AIM web site for specifications at:

<http://www.aimi.org/>

b Command - 2D Bar Code - PDF417 Specific Options



The following parameters may be omitted and default values will automatically be inserted. Each parameter value (data string) must be preceded by its associated command prefix character.

p₆ (s) = sets error correction level
Error Correction codewords per symbol
Values: **s1** - **s8**
If level is not specified, a level will automatically be assigned as per the following table:

EC level	EC Codewords	Auto Select Level
0	2	—
1	4	0-31
2	8	32-63
3	16	64-127
4	32	128-255
5	64	256-511
6	128	512-928
7	256	—
8	512	—

p₇ (c) = selects data compaction (compression) method
Values: **0** or **1**, default is **0**

c0 = Auto-encoding
The printer will switch between the three compaction modes as needed to create the smallest possible symbol for the given data.

c1 = Binary mode
The printer will encode the symbol in byte compaction mode.

PDF417 uses an intermediate data type called a “codeword” to store the characters in the symbol. Each codeword typically consumes a fixed-size portion of the total symbol. More characters inserted into a codeword results in fewer codewords needed to create a symbol. This results in a smaller symbol. To provide efficient data compaction, PDF-417 supports three types of codewords: text, numeric and binary.

b Command - 2D Bar Code - PDF417 Specific Options

Auto-Encoding (**c0**) data compaction method is set by default, and provides the best compaction. If Binary data compaction (**c1**) is selected the symbol will typically be larger. Binary data compaction may help to minimize the amount of time it takes a system to scan and decode the data encoded within the symbol.

Data Type	Compaction (Byte by Byte)
Text	2 Characters per codeword
Numeric	2.93 Characters per codeword
Binary	1.2 Bytes per codeword

- Text compaction can be used for uppercase, lowercase, numbers, space, carriage return, tab, line feed, and the following characters:

&,:#-.\$/+%*= ^ ;@N_ '~!|"(){}`

With text compaction, up to two characters can be encoded in a single codeword.

- Numeric compaction can be used for numbers only. Up to 2.93 characters can be encoded in a single codeword.
- Byte compaction can be used for any character. But the flexibility comes at a price; byte compaction encodes only 1.2 characters per codeword.

p₈ (p_{xxx},y_{yyy},m_{mm}) = print human readable
This parameter is a non-standard implementor of the PDF417 and is only recommended for troubleshooting purposes. Additional variables:

p = "p" - parameter identifier
xxx = horizontal start location
yyy = vertical start location
mm = maximum characters per line

b Command - 2D Bar Code - PDF417 Specific Options

- p₉ (f)** = Bar code origin point
Values: **0** or **1**, Default is **1**
f1- Center of bar code as defined by the automatically adjusted symbol size, i.e. width and height. Parameters **p₄** and **p₅** values are maximum values only.
f0- Upper left corner of bar code.
- P10 (x)** - module width (in dots)
Values: **2 - 9** (i.e. x2-x9)
Default: Auto selects **6** (dots). Tests data with maximum size limit set by **p₄** and **p₅** and then the other optional parameters. The printer automatically reduces the module width in one dot increments until the data fits within the symbols maximum dimensions (and other applied parameters) or until **3** dots has failed, then reports an error.
- P11 (y)** - set bar height (in dots)
Range: **4 - 99** (i.e. y4-y99)
Default: 4 times module width (**p₁₀**)
- P12 (r)** - maximum row count
Maximum limit for the number of rows to be used for auto selecting symbol features.
- P13 (l)** - maximum column count
Maximum limit for the number of columns to be used for auto selecting symbol features.
- P14 (t)** - truncated flag - legal values are:
0 = not truncated, **1** = truncated
See the PDF 417 specification for details.
- P15 (o)** - rotation
Values: **0**= 0°, **1**= 90°, **2**= 180°, **3**= 270°
Settings of 90° & 270° will cause the symbols maximum height (**p₄**) and width (**p₅**) values to transpose when automatically calculating and generating the symbol, i.e. the height would affect column dimensions and width would affect row dimensions.

b Command - 2D Bar Code - PDF417 Specific Options

“DATA” = ASCII data or Binary data bytes
Represents a fixed data field.

The backslash (\) character designates the following character is a literal and will encode into the data field. Refer to the following examples:

<u>To Print</u>	<u>Enter into data field</u>
“	\”
“Company”	\”Company\”
\	\\
\code\	\\code\\
↵	↵

PDF417: General Information A PDF417 symbol is organized into minimum of 3 to a maximum of 90 rows and a minimum of 5 to a maximum of 34 columns of codewords.

Each codeword is 17 modules wide. There are 4 bars and 4 spaces per codeword.

Multiply the module width (in dots, **P10**) by 17 to get the codeword width.

Multiply the module height (in dots, **P11**) by the number of rows to get the symbol height.

Four of the codewords in each row are start, stop and two row indicators. The remaining codewords are referred to as the data region and contain symbol overhead and compacted data.

There can be no more than 928 codewords in the data region. **All combinations of rows and columns are not legal**; 90 rows times 30 columns would produce a data region of 2700 codewords which exceeds the 928 codeword maximum per symbol. See the following table (on the next page) that shows the maximum number of rows and the resulting number of codewords in the data region for each column count.

b Command - 2D Bar Code - PDF417 Specific Options

PDF417 Symbol Geometry

Columns	Maximum Rows	Codewords
5	90	90
6	90	180
7	90	270
8	90	360
9	90	450
10	90	540
11	90	630
12	90	720
13	90	810
14	90	900
15	84	924
16	77	924
17	71	923
18	66	924
19	61	915
20	58	928
21	54	918
22	51	918
23	48	912
24	46	920
25	44	924
26	42	924
27	40	920
28	38	912
29	37	925
30	35	910
31	34	918
32	33	924
33	32	928
34	30	900

b Command - 2D Bar Code - PDF417 Specific Options

Automatic PDF 417 Bar Code Generation The printer automatically tests and changes the PDF 417 bar code geometry to maximize the readability of the bar code for a given maximum height and width, specified by **P4** and **P5**.

The printer tests the PDF 417 parameters in this order for a given data string (error correction and compression included):

1. Module width **P10** (for codeword width)
2. Symbol width **P4**
3. Symbol column maximum **P13**
4. Module height **P11**
5. Symbol height **P5**
6. Symbol row maximum **P12**

The printer will start with the maximum value (default or explicit) for these parameters. The printer reduces these values to get the module width and height to maximize readability.

b Command - 2D Bar Code - PDF417 Specific Options

Example: N ↵

b80,100,P,700,600,x2,y7,l100,r100,f0,s5," \ ↵

Fourscore and seven years ago our fathers brought forth on this continent a new nation, conceived in liberty and dedicated to the proposition that all men are created equal. Now we are engaged in a great civil war, testing whether that nation or any nation so conceived and so dedicated can long endure.

“ ↵

↵

b80,200,P,400,300,p40,440,20,f1,x3,y10,r60,l5,"ABCDEFGHIJK1234567890abcdefghijkl" ↵

P ↵

Will Produce:

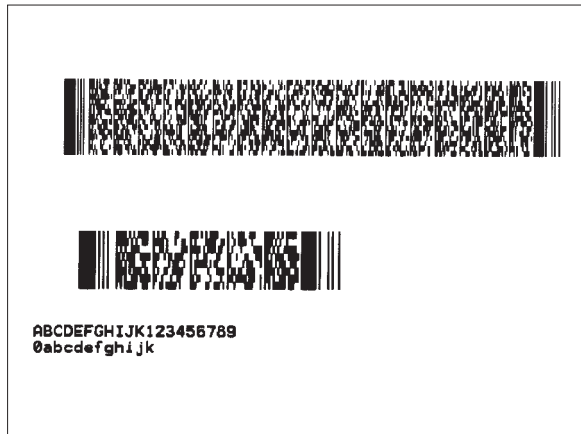

The second symbol has been set to print human readable data with the **p8** parameter (p40,440,20) and is not part of the PDF417 symbol.

C Command - Counter

Description The counter (**C**) command defines one of 10 automatic counters used in consecutive numbering applications (i.e. serial numbers). Counters must be defined **after** variables.



For Numeric Serialization Only. The counter function does not support Alpha or Alpha-Numeric Serialization.

Syntax **C***p*₁, *p*₂, *p*₃, *p*₄, “[**-**]PROMPT”

Parameters *p*₁ = Counter number. Range: **0** to **9**

*p*₂ = Maximum number of digits for counter.
Range: **1** to **29**

*p*₃ = Field Justification.
L = Left **R** = Right
C = Center **N** = No Justification

*p*₄ = Step Value. **+** or **-** sign followed by a single digit of **1 - 9**. Using a step value of **+0** allows the counter to be used as an additional variable data field.

“**PROMPT**” = An ASCII text field that will be transmitted to the KDU or host (via the serial interface) each time the command is executed. Typically used to request the operator to enter a starting counter value.

KDU Prompt Options [**-**] = Having the first character of the prompt a single minus sign will cause the prompt to display only once after form retrieval.

C Command - Counter

The **C** command is used in forms that require sequential numbering. When initializing counters, they must be defined in order (e.g. C0 first, C1 second...).

Field justification (**p₃**) affects the printing of counter data. When **L**, **R** or **C** are selected, the counter field is the width of **p₂** value. Data will justify within the counter (**p₂**) field per the selected **p₃**. The **N** parameter will print the minimum number of characters.

To print the contents of the counter, the counter number is referenced in the "**DATA**" field of the **A** (ASCII text) or **B** (Bar Code) commands.



If the starting value of a counter is "**1**", then no leading zero padding will be added. If the starting value is "**01**", then the counter will be padded, up to the maximum number of digits (**p₂**), with zeros.

Example: C0,10,L,+1,"-Enter Serial Number:" ↵

Saving and Protecting Consecutive Numbers in Nonvolatile Memory

This feature is useful when the counter field represents a serial number (or others types of numbers) that should never be repeated. This feature allows for automatic retrieval and increment (or decrement) of the previous counter value used every time a form is retrieved (and printed).

By placing one minus sign as the first character of the prompt, the prompt will appear only once after the form is retrieved, thereby protecting the integrity of the data.

Single Digit Summation with Counters

Add or subtract a single digit from the recalled counter value in a form. If form recalled counter **C0** had a value of **3**, then processing **C0+1** would yield a value of **4** and **C0-2** would yield a value of **1**.

C Command - Cut Immediate

Description: This command allows the printer to initiate an immediate media cut without a form print operation. The printer must have the cutter option installed.

- ❑ The **C** command – Cut Immediate **can not** be used inside of a form.
- ❑ The initial character **C** in a command string is used for both the Cut Immediate (**C**) and Counter Command function (**Cp₁**) which can only be used within a form. The Cut Immediate Command (**C**) can not be used in a form.
- ❑ The **C** command – Cut Immediate can not be used with the KDU.

Mobile printers, such as the TR 220, ignore this command.

Syntax: **C**

Parameters: None

Example: C↵



Only cut label liner (backing) or tag stock. Label adhesive will built up on the cutter blade and cause the cutter to operate poorly or jam if the labels are cut along with the label liner.



Use the **C** command - Cut Immediate 5 times without media loaded, to perform a self cleaning of the cutter blade.

D Command - Density

Description Use this command to select the print density.

Syntax **Dp₁**

Parameters **p₁** = Density setting. Acceptable values are:

Model	Acceptable Values ¹	Default Value
2722	0 - 15	7
2742	0 - 15	7
3742	0 - 15	7
2443 (Orion)	0 - 15	10
2824	0 - 15	7
2844	0 - 15	10
3842	0 - 15	7
Ht-146	0 - 15	7
2746 / 2746e	0 - 15	7
2684 (Strata)	0 - 15	7

Note 1: 0 is the lightest print and 15 is the darkest.

The density command controls the amount of heat produced by the print head. More heat will produce a darker image. Too much heat can cause the printed image to distort.



The density and speed commands can dramatically affect print quality. Changes in the speed setting typically require a change to the print density.

Example **D5**↵ : selects density 5

dump Command - Enable Dump Mode

Description This command allows the advanced programmer to force a user diagnostic “data dump” mode. Sending the dump command to the printer allows the programmer to compare actual data sent to printer with the host program.

Send data to the printer after the dump command has been issued to evaluate program and printer control data. The printer will process all data bytes into ASCII character data, range 0-255 decimal (00-FF hexadecimal).

Press the printer’s Feed button until “Out of Dump” is printed or power cycle the printer to terminate the dump mode.

Syntax **dump**

Parameters None

- ❑ Set the image buffer width with the **q** command to match the media width prior to issuing the **dump** command.
- ❑ Use the “Dump Mode” character map in Appendix A to interpret the dump mode data (characters printed on the labels) back into ASCII data.
- ❑ Press the Feed button to view dump data that exceeds a single label’s print area. Repeat to view more dump data as required.
- ❑ Pressing the Feed button after the dump data is finished printing will cause the printer to exit the dump mode.
- ❑ Graphics data dump may be large and require multiple labels to print.

Example `dump` ↵

eR Command - User Defined Error/Status Character

Description This command allows the advanced programmer to specify the printer's error/status report character for error reporting via the RS-232 serial interface.

Mobile printers, such as the TR 220, ignore this command.

Syntax eRp₁,p₂

Parameters p₁ = Any single ASCII character
Range: 0-255 decimal (00-FF hexadecimal)

p₂ = Error/Status Response Mode

p ₂	Mode Descriptions
0	Standard (default): XON (17 dec. / 11 hex.) on Recovery XOFF (19 dec. / 13 hex.) on Error
1	Character Only: Reports the selected error/status character followed by a Carriage Return and Line Feed.
2	Character & Error/Status Code: Reports the selected error/status character, error/status code (see page 3-126 for codes), and then by a Carriage Return and Line Feed.

Example For Mode 2 Error and Status Reporting:

eR\$,2↵ : Sets Error Character to "\$" and
: Sets Error Mode to "2".

↵ : User operates and prints with printer.
↵ : User opens print head.

\$11↵ : Reports Print Head Open

↵ : User closes print head

\$00↵ : Reports No Error
: Printer Ready for next command.
: (Status report for Print Head Closed)

El Command - Print Soft Font Information

Description This command will cause the printer to print a list of all soft fonts that are stored in memory.

Syntax El↵



Soft fonts can be downloaded to and deleted from the printer from the Soft Font Downloader Utility, CAL Tools or CAL3 software.

Example El↵ :prints soft font list

Will Produce

```
Ext. font information:  
a:096char,022dots,0dir.  
Ext font memory left: 050K
```

EK Command - Delete Soft Font

Description This command is used to delete soft fonts from memory.



Soft fonts can be downloaded to and deleted from the printer from the Soft Font Downloader Utility, CAL Tools or CAL3.

Syntax **EK {"FONTNAME"|"*"}**

Parameters **"FONTNAME"** = By entering the name of a font, that font will be deleted from memory.

"*" = By including an "*" (wild card), ALL fonts will be deleted from memory.

Example EK"A" ↵ :deletes font "A"
EK"*" ↵ :deletes all fonts

ES Command - Store Soft Font

Description This command is used to download and store soft fonts in memory.



Soft fonts can be downloaded to and deleted from the printer from the Soft Font Downloader Utility, CAL Tools or CAL3.

Syntax **ES"FONTNAME"p₁p₂p₃a₁b₁c₁"DATA₁"a₂b₂c₂"DATA₂" ... a_nb_nc_n"DATA_n"**

Parameters **"FONTNAME"** = One letter font name
Range: a-z, Lower Case

- Lower Case named fonts minimize soft font memory usage to only store fonts downloaded and have 256 character limit.

The following use hexadecimal coding for parameter values.

p₁: Number of characters to be downloaded
Range: 00 - FF hex. (0-255 decimal)
for 1 to 256 fonts per soft font set.

p₂: Character Rotation

- 00 hex. = 0 and 180 degrees
- 01 hex. = 90 and 270 degrees (clockwise)
- 02 hex. = Both 0 and 180 degree rotation pair and the 90 and 270 degree rotation pair

p₃: Font Height
Range: 00 to FF hex.
Measured in dots and expressed as a hexadecimal number, i.e. 1B hex. = 27 dots
Font height includes accentors and dis-senters of characters and need to fit in the character cell

- 203 dpi printers =
256 dots = 1.26 inches = 32.03 mm
- 300 dpi printers = 00 to FF hex.
256 dots = 0.85 inches = 21.67 mm

ES Command - Store Soft Font

a₁: (1st) Download Character (map position)
Range: 00 to FF hex.

b₁: (1st) Spacing To Next Print Character
Downloaded character's next printed character position in dots, i.e. Character tracking - the space between characters. Must be greater than or equal to the character width, see parameter **c₁**. Dots in a decimal number converted to a hexadecimal number.
Range: 00 to FF hex.

c₁: (1st) Downloaded Character's Width
Dots in a decimal number converted to a hexadecimal number.
Range: 00 to FF hex.

"DATA₁" : (1st) Character Bitmap
p₃ × c₁ = bit map data (in bytes)
Data is received in bytes, on a line by line basis. The font character's 0,0 cell map position is in the top left corner of the map as viewed in the 0 degree rotation. See the examples on the following pages.

a₂: (2nd) Download Character (map position)

b₂: (2nd) Spacing To Next Print Character

c₂: (2nd) Downloaded Character's Width

"DATA₂": (2nd) Character Bitmap
p₃ × c₂ bytes = bit map data

Repeat for each character until the last character in the set is downloaded.

a_n: (Last) Download Character (map position)

b_n: (Last) Spacing To Next Print Character

c_n: (Last) Downloaded Character's Width

"DATA_n" : Character Bitmap
p₃ × c_n bytes = bit map data

ES Command - Store Soft Font

For fonts with the rotation parameter set for “both” ($p_2 = 02$ hex.):

Repeat the individual font character download for each 90° rotated character from the start of the character set until the last rotated character in the set is downloaded.

a_{1-90° b_{1-90° c_{1-90° “DATA $_{1-90^\circ}$ ”
 a_{2-90° b_{2-90° c_{2-90° “DATA $_{2-90^\circ}$ ”
 a_{3-90° b_{3-90° c_{3-90° “DATA $_{3-90^\circ}$ ”

a_{n-90° : (Last) Download Character

b_{n-90° : (Last) Spacing To Next Print Character

c_{n-90° : (Last) Downloaded Character’s Width

“DATA $_{n-90^\circ}$ ” : Character Bitmap
 $p_3 \times c_n$ bytes = bit map data
 The number of individual character maps downloaded will be double the characters in the font set (p_1).

*Example of
Measuring Soft Font
Size*

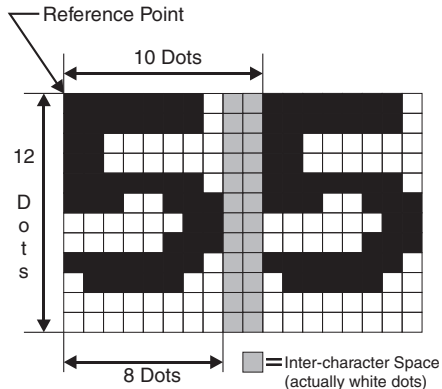

Parameter	Dots	Data Entered as Hexadecimal
p_3	12	0C hex.
b	10	0A hex.
c	8	08 hex.

ES Command - Store Soft Font

Soft Fonts Programming Code Example The typical soft font download command strings to the printer. The following example was generated with the CAL3 software.

```

00000000 0D 0A 45 4B 22 61 22 0D 0A 45 53 22 61 22 03 00  ..EK"a"...ES"a"...
           ↑           ↑           ↑   ↑
           CR & LF    CR & LF    P1  P2

00000010 1A 41 17 03 00 7C 00 00 7C 00 00 7C 00 00 EE 00  .A...|...|...|...
           ↑   ↑   ↑   ↑
           p3 a1 b1 c1

00000020 00 EE 00 01 EF 00 01 C7 00 01 C7 00 03 83 80 03  .....
00000030 83 80 07 83 C0 07 01 C0 07 01 C0 0E 00 E0 0F FF  .....
00000040 E0 0F FF E0 1F FF F0 1C 00 70 3C 00 78 38 00 38  .....p<.x8.8
00000050 38 00 38 70 00 1C 70 00 1C F0 00 1E E0 00 0E 00  8.8p..p.....
00000060 00 00 42 17 03 1F FF 00 1F FF C0 1F FF E0 1C 01  ..B.....
           ↑   ↑   ↑
           a2 b2 c2

00000070 E0 1C 00 F0 1C 00 70 1C 00 70 1C 00 70 1C 00 E0  .....p..p..p...
00000080 1C 01 E0 1F FF C0 1F FF C0 1F FF E0 1C 00 F0 1C  .....
00000090 00 70 1C 00 38 1C 00 38 1C 00 38 1C 00 38 1C 00  .p..8..8..8..8..
000000A0 38 1C 00 70 1C 00 F0 1F FF E0 1F FF C0 1F FF 00  8..p.....
000000B0 00 00 00 43 19 03 00 7F 00 01 FF C0 03 FF E0 07  ...C.....
           ↑   ↑   ↑
           a3 b3 c3

000000C0 C1 F0 0F 00 78 1E 00 38 1C 00 3C 1C 00 18 3C 00  ...x..8..<...<.
000000D0 00 38 00 00 38 00 00 38 00 00 38 00 00 38 00 00  .8..8..8..8..8..
000000E0 38 00 00 38 00 00 1C 00 0C 1C 00 0E 1C 00 1C 0E  8..8.....
000000F0 00 3C 0F 00 7C 07 C0 F8 03 FF F0 01 FF E0 00 7F  .<..|.....
00000100 80 00 00 00 0D 0A
           ↑
           CR & LF

```

ES Command - Store Soft Font

Font Bitmap Data Format

The black and white bitmap that represents the font must be converted into ASCII hexadecimal code. The 0° font format has dot converted to data bytes reading from left to right and the last byte in a line is padded with zeros to complete the line and data byte.

Starting Point

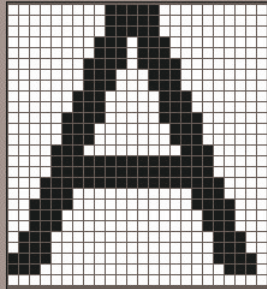

```
Line 1 - 00000000 01111100 00000000 = 00 7C 00
Line 2 - 00000000 01111100 00000000 = 00 7C 00
Line 3 - 00000000 01111100 00000000 = 00 7C 00
Line 4 - 00000000 11111110 00000000 = 00 FE 00
...
...
```

0° Data

```
00 7C 00 00 7C 00 00 7C 00 00 FE 00 ...
```

The 0° and 90° font data is then sent to the printer in line order.

Starting Point

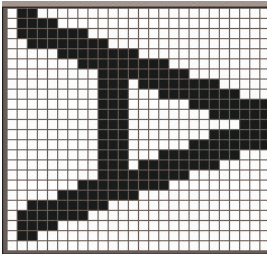

```
Line 1 - 01 10000000 00000000 00000000 = 01 80 00 00
Line 2 - 01 11100000 00000000 00000000 = 01 E0 00 00
Line 3 - 01 11111100 00000000 00000000 = 01 FC 00 00
Line 4 - 00 11111111 00000000 00000000 = 00 FF 00 00
...
...
```

90° Data

```
01 80 00 00 01 E0 00 00 01 FC 00 00 00 FF 00 00 ...
```

f Command - Cut Position

Description Use this command on an individual printer to provide precision cut placement to:

- Compensate for small sensor to cutter position differences on a printer by printer basis.
- Fine-tune the cut position to compensate for differences in media.

Mobile printers, such as the TR 220, ignore this command.

Syntax **fp₁**

Parameters **p₁** = Cut position index measured in dots. Acceptable values: 070 to 130. The default value is 100.

When using the label liner cutter option, the printer will advance each printed label to the appropriate programmed offset cut position, between labels, before cutting. Due to media differences, the printer may not accurately position the labels before cutting, causing the cutter to cut the label instead of the liner.



The printer's cutter is not designed to cut labels. Labels have adhesive that may interfere with the proper operation of the cutter.

Only cut label liner and tag stock and do not exceed the specified media density and thickness of the cutter.

If the cut position causes the label just printed to be cut, increase the cut position index value (>100). If the cut position causes the label following the one just printed to be cut, decrease the cut position index value (<100).

FE Command - End Form Store

Description This command is used to end a form store sequence.

Syntax **FE**

Example FS"FORMNAME"↵
...
FE↵

The form store sequence is started with the **FS** command.

FI Command - Print Form Information

Description This command will cause the printer to print a list of all forms stored in memory.

Syntax **FI**

Example FI↓ :prints forms list

Will Produce

```
Form information:  
1  
TESTFORM  
Form memory left:004.9K
```

FK Command - Delete Form

Description This command is used to delete forms from memory.

Syntax **FK** [**"FORMNAME"** | **"**"**]

Parameters **"FORMNAME"** = By entering the name of a form, that form will be deleted from memory.

- The name may be up to **8 characters** long.
- Form names stored by the printer are case sensitive and will be stored exactly as entered on the **FS** command line; i.e. **"FORM1"**, **"form1"** and **"FoRm1"** are three different forms when stored into the printer or when retrieved by the user.
- Deleting a single form requires the **FK"FORMNAME"** be issued twice for each form to be deleted. Some label generation programs re-issue forms (form delete and store) every time a label is printed which reduces flash memory life.

""** = By including an "*" (wild card), ALL forms will be deleted from memory. The **FK"**"** does not need to be issued twice to delete all forms.

Example **FK"AFORM"** ↵ :deletes form "AFORM"
FK"AFORM" ↵ :second delete form "AFORM" required
:for flash printers

FK""** ↵ :deletes all forms

FR Command - Retrieve Form

Description Use this command to retrieve a form that was previously stored in memory.

Syntax **FR"FORMNAME"**

Parameters **"FORMNAME"** = This is the form name used when the form was stored.

- The name may be up to **8 characters** long.
- Form names stored by the printer are case sensitive and will be stored exactly as entered on the **FS** command line; i.e. **"FORM1"**, **"form1"** and **"FoRm1"** are three different forms when stored into the printer or when retrieved by the user.

Example FR"TEST1" ↵ :retrieves the form named TEST1

To print a list of the forms currently stored in memory, use the **FI** command.

FS Command - Store Form

Description This command begins a form store sequence.

Syntax **FS"FORMNAME"**

- Parameters** **"FORMNAME"** = This is the form name that will be used when retrieving the stored form.
- The name may be up to **8 characters** long.
 - Form names stored by the printer are case sensitive and will be stored exactly as entered on the **FS** command line; i.e. **"FORM1"**, **"form1"** and **"FoRm1"** are three different forms when stored into the printer or when retrieved by the user.
 - Global commands such as **EI, EK, ES, FI, FK, GI, GK, GM, M, N, P, TS, U, UE, UF, UG, Y, W, ?, ^@** should not be used in a form store sequence.



Form name, **AUTOFR**, is reserved for automatic, single form recall, see page 3-9 for details.

- All commands following **FS** will be stored in form memory until the **FE** command is received, ending the form store process.
- Delete a form prior to updating the form by using the **FK** command. If a form (with the same name) is already stored in memory, issuing the **FS** command will result in an error and the previously stored form is retained.
- To print a list of the forms currently stored in memory, use the **FI** command.
- Data stored within a form can not have the Null (0 dec. 00 hex.) character as part of any data within that form.
- A form will not store if insufficient memory is available. See the **M** command for details on adjusting and configuring memory for forms, graphics and soft fonts.

FS Command - Store Form

Example ↵

FK"TESTFORM" ↵ :delete form "TESTFORM"
FS"TESTFORM" ↵ :begins the form store sequence of
:the form "TESTFORM"
V00,15,N,"Enter Product Name:" ↵
B10,20,0,3,2,10,100,B,"998152.001" ↵
A50,200,0,3,1,1,N,"Example Form" ↵
A50,400,0,3,1,1,N,"Model Name: "V00 ↵

FE ↵ :ends form store sequence
FI ↵ :prints list of stored forms

GG Command - Print Graphics

Description Use this command to print a PCX (format) graphic that has been previously stored in printer memory.

Syntax **GGp₁,p₂,{"NAME" | Variable Data}**

Parameters **p₁** = Horizontal start position (X) in dots.

p₂ = Vertical start position (Y) in dots.

"NAME" or Variable Data = This is the graphic name used when the graphic was stored. This name can be supplied via variable data (**V00 - V99**).

- The name may be up to **8 characters** long.
- Graphic names stored by the printer are case sensitive and will be stored exactly as entered with the **GM** command line; i.e. **"GRAPHIC1"**, **"graphic1"** and **"graPHic1"** are three different graphics when stored into the printer or when retrieved by the user.

Example: GG50,50,"LOGO1" ↵

```
FK"TESTFORM" ↵ :delete form "TESTFORM"  
FS"TESTFORM" ↵ :begins the form store sequence of  
:the form "TESTFORM"  
V00,8,N,"Enter Graphic Name:" ↵  
GG50,50,V00 ↵  
FE ↵ :ends form store sequence  
  
FR"TESTFORM" :retrieves the form named TESTFORM  
? ↵ :Download variables  
LOGO1 :Graphic name to be recalled and  
:printed  
  
P1 ↵ :Print one label with graphic LOGO1
```

GI Command - Print Graphics Information

Description This command will cause the printer to print a list of all graphics stored in memory.

Syntax **GI**

Example GI↓ :prints graphics list

Will Produce

```
Graphics information:  
LOGO  
Graphics memory left:003K
```

GK Command - Delete Graphics

Description Use this command to delete graphics from memory.

Syntax **GK {"NAME"|"*"}**

Parameters **"NAME"** = By entering the name of a graphic, that graphic will be deleted from memory.

- Graphic names stored by the printer are case sensitive and will be stored exactly as entered with the **GM** command line; i.e. **"LOGO1"**, **"logo1"** and **"LoGo1"** are three different graphics when stored into the printer or when retrieved by the user.
- Deleting a single graphic requires that the **GK"FORMNAME"** command string be issued twice for each form deleted. Some label generation programs re-issue graphics (graphic delete and store) every time a label is printed which will reduce flash memory life.

"*" = By including an "*" (wild card), ALL graphics will be deleted from memory. The **GK"*"** does not need to be issued twice to delete all graphics.

Example: GK"LOGO" ↵ :deletes graphic "LOGO"
GK"LOGO" ↵ :second delete graphic "LOGO" required
:for flash printers.

GK"*" ↵ :deletes all graphics

GM Command - Store Graphics

Description Use this command to store PCX graphics files in memory.

Syntax **GM**"NAME"**p**₁␣
"DATA"

Parameters "NAME" = This is the graphic name that will be used when retrieving the stored graphic.

- The name may be up to **8 characters** long.
- Graphic names stored by the printer are case sensitive and will be stored exactly as entered with the **GM** command line; i.e. "**LOGO1**", "**logo1**" and "**LoGo1**" are three different graphics when stored into the printer or when retrieved by the user.

p₁ = This is the file size in bytes. Use the DOS DIR command to determine the exact file size.

"DATA" = Graphic data in 1-bit (black & white) PCX (binary data) format file.

- A graphic will not store if sufficient memory is not allocated to graphic memory. See the **M** command for details on adjusting and configuring memory to store graphics (forms and soft fonts).
- Verify the proper storage of the graphic with the **GI** command.

GM Command - Store Graphics

Example GK"LOGO1"
GK"LOGO1"
GM"LOGO1"584
DATA

:deletes graphic "LOGO1" - Required
:second delete graphic - Required
:Prepares printer to receive graphic
:"LOGO1"
: Data string in PCX format

If using a DOS system, the PCX format file (binary data) portion can be sent to the printer using the DOS COPY command. For example, if you have a PCX file named LOGO1.PCX in your current directory, the appropriate command would be:

COPY LOGO1.PCX PRN /b

After downloading, the **GI** command can be used to verify that the graphic was successfully stored.

Example First, create a text file "STOREIT.TXT" with an ASCII text editor, as follows:

GK"WORLD"
GK"WORLD"
GM"WORLD"2004

Where WORLD is the name of the graphic and 2004 is the size (in bytes) of the PCX file.

DO NOT add extra linefeeds to the STOREIT.TXT file.

Next, at the DOS prompt, type:

COPY STOREIT.TXT + WORLD.PCX PRN /b

or use the Zebra Firmware Downloader from Windows OS download the STOREIT.TXT and WORLD.PCX in sequence to the printer.

GW Command - Direct Graphic Write

Description Use this command to load binary graphic data directly into the *Image Buffer* memory for immediate printing. The printer does not store graphic data sent directly to the image buffer.

The graphic data is lost when the image has finished printing, power is removed or the printer is reset. Commands that size (**Q** and **q**) or clear (**N** and **M**) the image buffer will also remove graphic image data.

Syntax **GW****p**₁,**p**₂,**p**₃,**p**₄**DATA**↵

Parameters **p**₁ = Horizontal start position (X) in dots.

p₂ = Vertical start position (Y) in dots.

p₃ = Width of graphic in bytes.
Eight (8) dots = One (1) byte of data

p₄ = Length of graphic in dots (or print lines).

DATA = Raw binary data without graphic file formatting. Data must be in bytes. Multiply the width in bytes (**p**₃) by the number of print lines (**p**₄) for the total amount of graphic data. The printer automatically calculates the exact size of the data block based upon this formula.

I Command - Character Set Selection

Description Use this command to select the appropriate character set for printing and display (KDU).

Syntax **I***p*₁,*p*₂:*p*₃

Parameters **p**₁ = Number of data bits - **8** for 8 bit data or **7** for 7 bit data.

p₂ = Printer Code page/Language Support

8 Bit Data			7 Bit Data	
P2	Code Page	Description	P2	Description
0	DOS 437	English - US	0	USA
1	DOS 850	Latin 1	1	British
2	DOS 852	Latin 2 (Cyrillic II/Slavic)	2	German
3	DOS 860	Portuguese	3	French
4	DOS 863	French Canadian	4	Danish
5	DOS 865	Nordic	5	Italian
6	DOS 857	Turkish	6	Spanish
7	DOS 861	Icelandic	7	Swedish
8	DOS 862	Hebrew	8	Swiss
9	DOS 855	Cyrillic		
10	DOS 866	Cyrillic CIS 1		
11	DOS 737	Greek		
12	DOS 851	Greek 1		
13	DOS 869	Greek 2		
A	Windows 1252	Latin 1		
B	Windows 1250	Latin 2		
C	Windows 1251	Cyrillic		
D	Windows 1253	Greek		
E	Windows 1254	Turkish		
F	Windows 1255	Hebrew		

I Command - Character Set Selection

P₃ = KDU Country Code (8 bit data only)

KDU Country Code (8 bit only)					
032	Belgium	049	Germany	027	S. Africa
002	Canada	031	Netherl'ds	034	Spain
045	Denmark	039	Italy	046	Sweden
358	Finland	003	Latin Am.	041	Swizerl'd
033	France	047	Norway	044	U.K.
		351	Portugal	001	U.S.A.

The default setting is **18,0,001**. See Appendix A for EPL2 standard font character maps.

JB Command - Disable Top Of Form Backup

Description This command disables the Top Of Form Backup feature when printing multiple labels. At power up, Top Of Form Backup will be enabled.

Syntax **JB**

Example: JB ↵



With the **JB** command enabled, the first label will backup to the Top Of Form before printing. This preserves the first label which has stopped approximately one-half inch from the print head. This is the label's tear away point as set by the previous print operation.

JC Command - Disable Top Of Form Backup- All Cases

Description This command disables the Top Of Form Backup feature for all operations. Use this command for liner-less printing and special media cutting modes.



This command only is available in the 2824, 2844, and 3842 desktop printer models at this time.

Syntax **JC**

Example: JC↓

JF Command - Enable Top Of Form Backup

Description This command enables the Top Of Form Backup feature and presents the last label of a batch print operation. Upon request initiating the printing of the next form (or batch), the last label backs up the Top Of Form before printing the next label.

Syntax **JF**

Example: JF↵

LE Command - Line Draw Exclusive OR

Description Use this command to draw lines with an “Exclusive OR” function. Any area, line, image or field that this line intersects or overlays will have the image reversed or inverted (sometimes known as reverse video or a negative image). In other words, all black will be reversed to white and all white will be reversed to black within the line’s area (width and length).

Syntax **LE***p*₁, *p*₂, *p*₃, *p*₄

Parameters **p**₁ = Horizontal start position (X) in dots.

p₂ = Vertical start position (Y) in dots.

p₃ = Horizontal length in dots.

p₄ = Vertical length in dots.

Example: N↵ :clear image buffer
LE50,200,400,20↵ :draw a line
LE200,50,20,400↵ :draw another line
P1↵ :print one label

Will Produce:

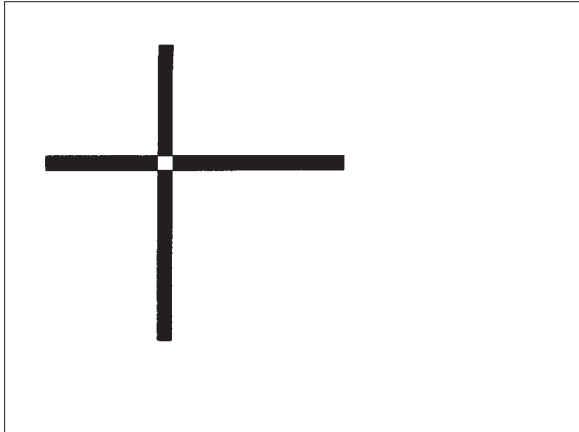

LO Command - Line Draw Black

Description Use this command to draw black lines, overwriting previous information.

Syntax **LO***p*₁,*p*₂,*p*₃,*p*₄

Parameters *p*₁ = Horizontal start position (X) in dots.

*p*₂ = Vertical start position (Y) in dots.

*p*₃ = Horizontal length in dots.

*p*₄ = Vertical length in dots.

Example: N↵ :clear image buffer
LO50,200,400,20↵ :draw a line
LO200,50,20,400↵ :draw another line
P1↵ :print one label

Will Produce:

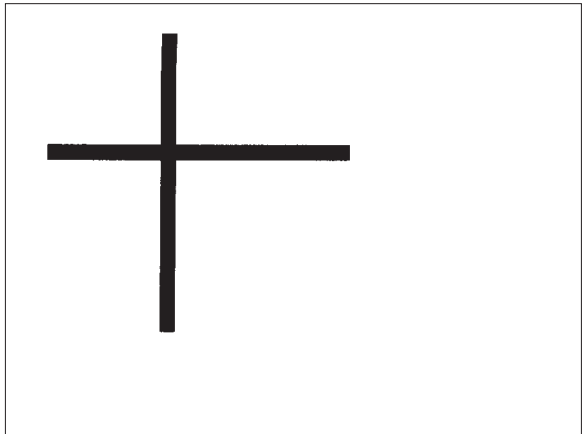

LS Command - Line Draw Diagonal

Description Use this command to draw diagonal black lines, overwriting previous information.

Syntax **LS***p₁,p₂,p₃,p₄,p₅*

Parameters **p₁** = Horizontal start position (X) in dots.

p₂ = Vertical start position (Y) in dots.

p₃ = Line thickness in dots.

p₄ = Horizontal end position (X) in dots.

p₅ = Vertical end position (Y) in dots.

Example: N ↵ :clear image buffer
LS10,10,20,200,200 ↵ :draw a diagonal line
P1 ↵ :print one label

Will Produce:

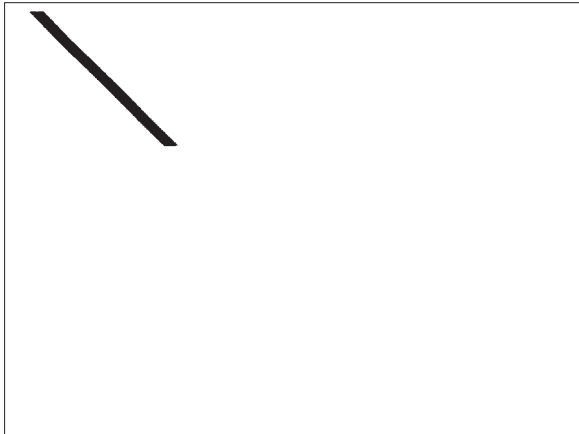

LW Command - Line Draw White

Description Use this command to draw white lines, effectively erasing previous information.

Syntax **LW***p*₁,*p*₂,*p*₃,*p*₄

Parameters **p**₁ = Horizontal start position (X) in dots.

p₂ = Vertical start position (Y) in dots.

p₃ = Horizontal length in dots.

p₄ = Vertical length in dots.

Example:

N↵	:clear image buffer
LO50,100,400,20↵	:draw black line
LO50,200,400,20↵	:draw another black line
LO50,300,400,20↵	:draw another black line
LW200,50,20,400↵	:draw a white line over all 3 black lines
P1↵	:print 1 label

Will Produce:



M Command - Memory Allocation

Description Use this command to set the size of form memory. The remainder of the form storage memory will be shared by soft fonts and graphics data.

For legacy printers, this command was originally used for memory configuration (partition) of forms, image buffer, graphics and soft fonts memory which was shared in legacy SRAM and early model flash printers.

Syntax **M***p₁*,*p₂*,*p₃*

Parameters **p₁** = Parameter ignored, but required to process. Represents Image buffer size in whole KBytes.

p₂ = Form(s) memory size in whole KBytes. The parameter, **p₂** (form memory size), inversely effects the size of the shared graphics/soft fonts memory.

p₃ = Parameter ignored, but required to process. Graphics (and soft font) memory size in whole Kbytes.

If the **M** command is issued, then all three parameters must be present.



Available memory and the current allocation of memory can be displayed with the **U** command or an AutoSense procedure, see the printer user's manual for details.

N Command - Clear Image Buffer

Description This command clears the image buffer prior to building a new label image.

Syntax **N**

- Considerations**
- ❑ Do not use the **N** command within stored forms.
 - ❑ All printer configuration commands should be issued prior to issuing the **N** command to begin building the image for printing within the image buffer.
 - ❑ Always send a Line Feed (**LF**) prior to the **N** command to ensure that previous data in the command buffer has cleared and the printer is initialized and ready to accept commands.

Example: ↵
N↵ :activates command processing
 :clears the image buffer

o Command - Cancel Software Options

Description This command allows the user to cancel most printer customization parameters set by o series commands.

Parameters set by the following commands are canceled and returned to default operation:

- oH
- oM
- oE

Syntax o

Parameters None

The o command is a global printer command.

It can not be issued inside of a form.

It must be issued prior to issuing a text or bar code command (and printing).

oB Command - Cancel Auto Bar Code Optimization

Description: This command allows the advanced programmer to disable bar code optimization for rotated (90° & 270°) bar codes.

Syntax: oB

Parameters: None

The oB command is a global printer command.

- It can not be issued inside of a form.
- It must be issued prior to issuing a bar code command (and printing).

To reapply bar code defaults, issue a o (small letter “o”) command. See page C-74 for important details on the effects of using the o command.

Reset the printer with a ^@ command with flash firmware printers or cycle printer power to clear the oB command and return the printer to normal operation.



Zebra Technologies Corporation does not warrant, support, or endorse the use of bar codes generated by the printer after a oB command has been issued.

Zebra Technologies Corporation does not support this feature other than with the information supplied in this document.

oE Command - Line Mode Font Substitution

Description: This command is a Page Mode (EPL2) command that allows the printer to set alternate **Line Mode** font character sets. The fonts are activated by the **oE** command and are intended for EPL1 emulation.

Mobile printers, such as the TR 220, ignore this command.

Syntax: **oEp₁.p₂.p₃.p₄.p₅**

p₁ = 5 x 7 bitmap font - Normal (CCSET4)
Line Mode EPL1 Compatibility Font A0
Total character area is 8 x 11 dots

p₂ = 5 x 7 bitmap font - Bold (CCSET4)
Line Mode EPL1 Compatibility Font A0
Total character area is 8 x 11 dots

p₃ = 5 x 7 bitmap font - Doubled (CCSET4)
Line Mode EPL1 Compatibility Font A0
Total character size is 8 x 11 dots

p₄ = 14 x 22 bitmap font - (CCSET1)
Line Mode EPL1 Compatability Font A
Total character area is 16 x 26 dots

p₅ = 10 x 18 bitmap font - (CCSET3)
Line Mode EPL1 Compatability Font A
Total character area is 12 x 22 dots

- Parameters **p₁-p₅** are preloaded soft fonts.
- Parameters **p₁-p₅** must be all belower case alpha soft fonts. See the **ES** command on page 3-45 for more details on soft fonts.
- The EPL2 font sets 2 & 4 can be restored as the default Line Mode fonts by sending the **o** command without a parameter.

oH Command - Macro PDF Offset

Description Use this command to place additional secondary, associated Macro PDF symbols for the continuation of data greater than a single PDF 417 bar code can store.



This command must precede any PDF 417 bar code commands in order to print Macro PDF (multiple bar code) symbols from a single **b** command's data field.

Syntax **oHp₁.p₂**

Parameters **p₁** = Horizontal offset position (X) in dots of the next Macro PDF bar code symbol.

p₂ = Vertical offset position (Y) in dots of the next Macro PDF bar code symbol.

See the following page for an example.

oH Command - Macro PDF Offset

Example: N␣
q784␣
Q1215,24␣
R0,0␣
oH0,500␣
␣
N␣
b80,100,P,700,600,x2,y7,l100,r100,f0,s5,"\
Fourscore and seven years ago our fathers...
<< the rest of Lincoln's Gettysburg Address HERE >>
... and that government of the people, by the people, for the people
shall not perish from the earth.
"␣
P␣

Will Produce:

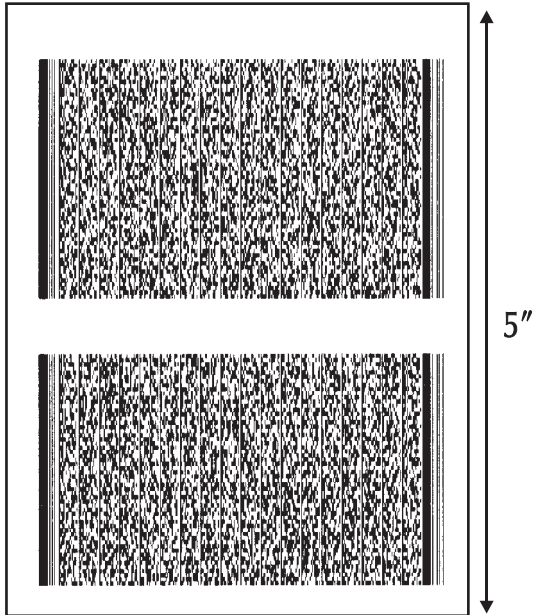

oM Command - Disable Initial Esc Sequence Feed

Description This command disables the automatic label calibration routine executed by the printer upon receiving the first escape command sequence from the Windows printer driver. The printer normally measures a single label and sets the top of form prior to printing the first label after a power-up reset. The Windows™ printer driver issues escape sequences when printing.

This command's primary use is to save preprinted forms such as serialized labels, tags or tickets.

Mobile printers, such as the TR 220, ignore this command.

Syntax oM

This command must be issued prior to printing with the Windows driver's or any other Escape (esc) mode printing operation.

To reinitialize label calibration, issue a o (111 dec. or 6F hex.) command.

oR Command - Character Substitution (Euro)

Description This command allows the advanced programmer to substitute the Euro currency character for any ASCII character in printer resident font numbers 1-4.

The second function this command supports is the zero character style toggling between a plain zero character and a zero with a slash.

Character substitution settings are stored in the printers non-volatile 'flash' memory. The original character can be restored by sending the **oR** command without a parameter.

Syntax **oR** [**p₁**,**p₂**]

Parameters: **p₁** = **E**

If the **p₂** parameter is not provided, then the Euro character will map to code page position 213 decimal (D5 hexadecimal) for all code pages.

p₁ = **0** (zero)
Toggles the zero character:
slash — no slash (out of box default)

p₂ = Decimal number
Range: 0 to 255
The active code page's ASCII character map position to be replaced by the Euro character. The Euro character will be active in this map position for all code pages. See the **I** command for details on code page selection.

None = No Parameters (**p₁/p₂**) resets to all code pages to original default character mapping.

Optionally, to reapply normal character operations, issue a **o** (111 dec. or 6F hex.) command. See page 3-74 for important details on the effects of using the **o** command.



The Euro character is not supported in Font 5 character set.

oR Command - Character Substitution (Euro)

The **oR** command is a global printer command.

- ❑ It can not be issued inside of a form.
- ❑ It must be issued prior to issuing a text command (and printing).
- ❑ Effects a single character on a single code page. Changing the character position will restore the original character.
- ❑ Flash memory printer parameter data is preserved until it is changed by the **oR** command or reprogramming of the printer.

Example: oRE↵ : Places the Euro character into character
: map position 213 decimal
: (D5 hexadecimal)

oRE,128↵ : Places the Euro into character map
: position 128 decimal (80 hexadecimal)

oR↵ : Clears Character Substitution,
: Restores default character maps

oW Command - Customize Bar Code Parameters

Description: This command allows the advanced programmer to modify specific bar code parameters to exceed the specified bar code's design tolerances, i.e. reduce the bar code size.



Using the **oW** command may cause bar codes to become unreadable by some or all bar code scanners.

Syntax: **oWp₁,p₂,p₃,p₄,p₅**

Parameters: **p₁** = Initial width narrow white bar.
Default value is 2

p₂ = Initial width narrow black bar.
Default value is 2

p₃ = Initial width wide white bar.
Default value is 4

p₄ = Initial width wide black bar.
Default value is 4

p₅ = Initial bar code gap.
Default value is 3

The **oW** command is a global printer command.

- They can not be issued inside of a form.
- They must be issued prior to issuing a bar code command (and printing).
- Use only one bar code format. Using more than one bar code may cause unpredictable results or operation.
- Issue all 5 command parameters (p1-5). Use the default parameter values as place holders.
- Bar code printed with this command should be printed in the picket fence orientation (0° & 180° rotations) to maximize scanning.

oW Command - Customize Bar Code Parameters

Reset the printer with a **^@** or **o** commands with flash firmware printers or cycle printer power to clear the **oW** command and return the printer to normal operation. See page C-74 for important details on the effects of using the **o** command.

The **B** command parameters **p5** & **p6** must be set to **0** to use bar codes customized with this command.



The **oW** command has been tested for parameter functionality for Bar Code 39 only. The **oW** command may also function with Codabar and Interleaved 2 of 5 bar code, but they have not been functionally verified for this command.



Zebra Technologies Corporation does not warrant, support, or endorse the use of bar codes generated by the printer after a **oW** command has been issued.

Zebra Technologies Corporation does not support this feature other than with the information supplied in this document.

○ Command - Hardware Options

Description Use this command to select various printer options. Options available vary by printer configuration.

Options selected and enabled in a printer can be verified by checking the printer configuration printout, Dump Mode printer status label. See the **U** command and the *Explanation of the Status Printout* on page 2-2.

Mobile printers, such as the TR 220, ignore this command.

Syntax **O**[**C**[**p**₁], **D**, **L**, **S**]

Parameters **D** = Enable **Direct Thermal Mode**, use this option when using direct thermal media in a thermal transfer printer.

d = Out of box default **Direct Thermal Mode** setting used in a 2844, 2824 or 3842 thermal transfer printer's and is displayed in the *Dump Mode status printout*. Changing the printer to thermal transfer mode or when the printer detects a transfer ribbon will cause this option parameter to permanently be removed from the status printout.

L = Enable **Label Dispense Mode - Tap to Print**. The printer will present each label and wait for a tap of the feed switch before printing the next label. Use this mode when printing multiple copies of liner-free labels.

Fp₁ = **Form Feed Setting**.

p₁ = Sets the type of operation the feed button .

f = Default, normal operation.
Tap to feed.

r = Reprint last label printed.

i = Ignore the feed button.

○ Command - Hardware Options

C = Enable optional **Label Liner Cutter**.
The cutter will cut at the end of each form as specified by the **Q** command.

Cp₁ = **Batch Print Labels and Liner Cut**.

p₁ = Sets the number of labels to print prior to cut.

If a number between 1 - 255 is specified for **p₁**, the printer will cut after the specified number of labels have been printed.

If **b** is specified for **p₁**, the “batch print & cut” feature is enabled. This feature uses the **P** command to control cutter operation.

S = Reverse the **Transmissive (Gap) Sensor Operation**.

Examples: 0	:disables all options.
0C	:enables cutter only, labels are cut after each label is printed, disables all other options
0D	:enables direct thermal mode on thermal transfer printers, disables all other options
0Cb	:labels are cut after a batch of five has printed,
...	:disables all other options
P5	:Sets the number of labels to print before the cut

OEPL1 Command - Set Line Mode

Description: This command is used to switch the printer operating mode from Page Mode (EPL2) to Line Mode (EPL1 emulation).

Line Mode configuration setting is retained after reset has been issued or power has been cycled.

Mobile printers, such as the TR 220, ignore this command.

Syntax **OEPL1**

Example: OEPL1↵

Returning to Page Mode The Line Mode command **EPL2** can be sent to the printer to return the printer to Page (EPL2) Mode operation.

The **EPL2** command is preceded by an **ESC**ape (27 dec or 1Bh) character and followed by a line feed (**LF** - 10 dec or 0A hex), a carriage return (**CR** - 13 dec or 0D hex) or **CR/LF**.

Example: ←EPL2↵

P Command - Print

Description Use this command to print the contents of the image buffer.

Syntax **P***p*₁, [*p*₂]

Parameters **p**₁ = Number of label sets.
Range = 1 to 65535

p₂ = Number of copies of each label (used in combination with counters to print multiple copies of the same label).
Range = 1 to 65535



The **P** command cannot be used inside of a stored form sequence. For automatic printing of stored forms, use the **PA** command.

Examples: P1 ↵ :prints one label set
P2,1 ↵ :prints 2 label sets of one label each
P5,2 ↵ :prints 5 label sets of 2 labels each

PA Command - Print Automatic

Description Use this command in a stored form sequence to automatically print the form (as soon as all variable data has been supplied).

Syntax **PA***p*₁, [*p*₂]

Parameters **p**₁ = Number of label sets. Can be variable data.
Range: 1 to 9999

p₂ = Number of copies of the same label.
Can be variable data.
Range: 1 to 9999
Sets the number of copies of each label (used in combination with counters) to print multiple copies of the same label.
This value is only set when using counters.

Example:

FK"1" ↵	: delete form named "1"
FS"1" ↵	: start form store sequence
V00,10,N,"prompt:" ↵	: define variable 00
V01,1,N,"prompt:" ↵	: define variable 01
V02,4,N,"prompt:" ↵	: define variable 02
A24,24,0,4,1,1,N,V00 ↵	: write a line of text including variable
PAV01,V02 ↵	: print 1 label automatically
FE ↵	: end form store sequence
FR"1" ↵	: retrieve form "1"
? ↵	: get variables
This Is Text ↵	: data for V00
3 ↵	: data for V01 = p ₁ - number of sets
2 ↵	: data for V02 = p ₂ - number of copies

q Command - Set Label Width

Description Use this command to set the width of the printable area of the media.

Syntax **qp₁**

Parameters **p₁** = The width of the label measured in dots. The **q** command will cause the image buffer to reformat and position to match the selected label width (**p₁**).

*Image Buffer
Positioning - Center
Aligned Printers*

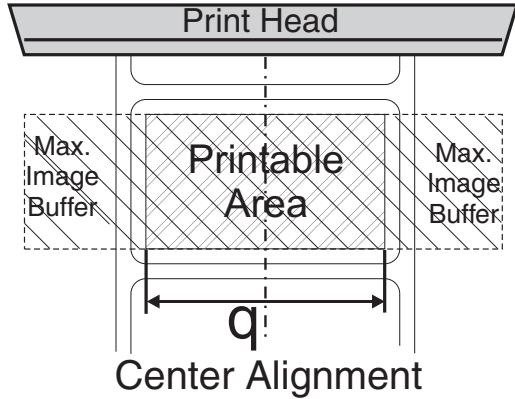

*Image Buffer
Positioning - Left
Aligned Printers*

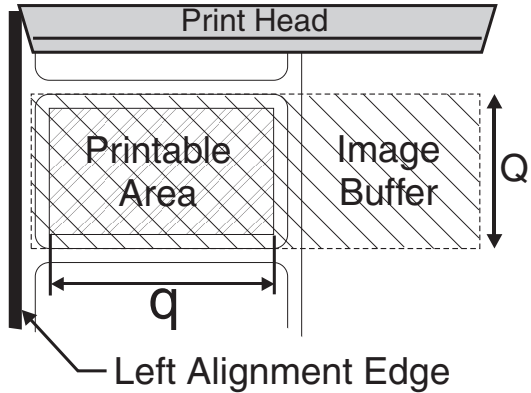

q Command - Set Label Width



All Printers

(Exceptions - 2746, 2746e & 2348)

This command will automatically set the left margin according to the following rules:

$$(\text{print head width} - \text{label width}) / 2$$



The **q** value affects the available print width. Minimizing the **q** value will maximize the print length and print speed (double buffering).



If the **R** Command (Reference Point) is sent after this command, the image buffer will be automatically reformatted to match the width of the print head and is offset by the **R** command specified image buffer starting point, nullifying the **q** command.

Example: q416↵

:sets label width to 416 dots wide

Q Command - Set Form Length

Description Use this command to set the form and gap length or black line thickness when using the transmissive (gap) sensor, black line sensor, or for setting the printer into the continuous media print mode.

The **Q** command will cause the printer to recalculate and reformat image buffer.

Syntax **Qp₁,p₂[±p₃]**

Parameters **p₁** = Label length measured in dots
Default: Set by the AutoSense of media.
Maximum Value: 65535 (dots)

- Distance between edges of the label or black line marks.
- For continuous mode, the **p₁** parameter sets the feed distance between the end of one form and beginning of the next.

p₂ = Gap length or thickness of black line
Range: 16-240 (dots) for 203 dpi printers
[18-240 (dots) for 300dpi printers]

Gap Mode - By default, the printer is in Gap mode and parameters are set with the media AutoSense.

Black Line Mode - Set **p₂** to **B** plus black line thickness in dots. See the Gap mode range.

Continuous Media Mode

Set **p₂** to 0 (zero)

The transmissive (gap) sensor will be used to detect the end of media.

±p₃ = Offset length measured in dots

- **Required for black line** mode operation.
- Optional for Gap detect or continuous media modes. Use only positive offset values.

Q Command - Set Form Length



AutoSense routine does not detect black line or continuous media.

All EPL2 printers have a transmissive (gap) sensor designed to detect the top of each label or tag. It does this in one of two ways:

- Sensing through the label liner at the gap between labels.
- Looking through a hole (notch) in the tag.

Printers equipped with a black line sensor can determine the top of each label or tag by sensing a “black line” preprinted on the media backing.



Sensor location is important when selecting the proper of label or tag type for printing. See the printer user’s manual for specific information on alignment, adjustment, and position of the transmissive (gap) or reflective (black line) sensors.



If the label size is not set properly, the printer may print off the edge of the label or tag and onto the backing or platen roller. Repeated printing off the edge of the label can cause excessive print head wear.

Maintain a minimum margin of 0.04 inches (1 mm) on all sides of the label.



Setting the label size to large can cause the printer to skip labels.

Q Command - Set Form Length

Examples:

Standard Label

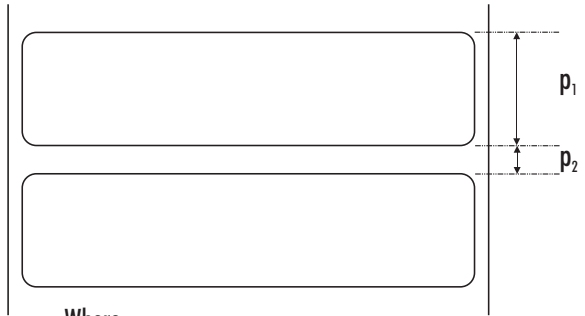

Where:

$p_1 = 20.0 \text{ mm (160 dots)}$

$p_2 = 3.0 \text{ mm (24 dots)}$

The Q command would be:

Q160,24↵

Butterfly Label

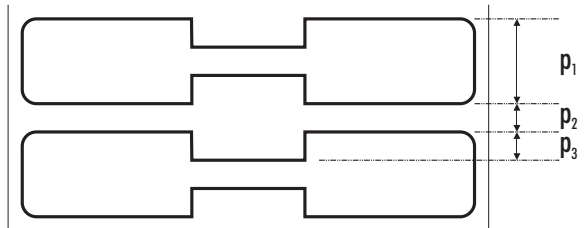

Where:

$p_1 = 12.5 \text{ mm (100 dots)}$

$p_2 = 3.0 \text{ mm (24 dots)}$

$p_3 = 3.0 \text{ mm (24 dots)}$

The Q command would be:

Q100,24 + 24↵

Q Command - Set Form Length

Black Line On Perforation

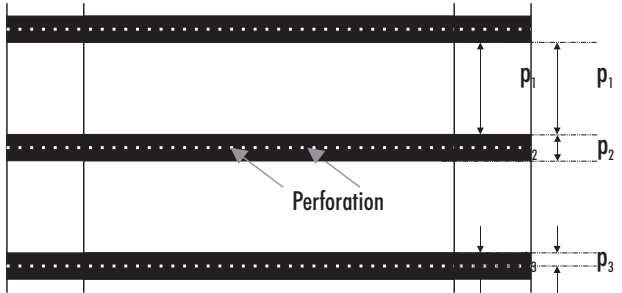

Where: Where:

$p_1 = 31.0 \text{ mm}$ (248 dots)

$p_2 = 7.0 \text{ mm}$ (56 dots)

$p_3 = 0.5 \text{ mm}$ (4 dots)

The Q command would be:

Q248,B56+4↵

Black Line Between Perforation

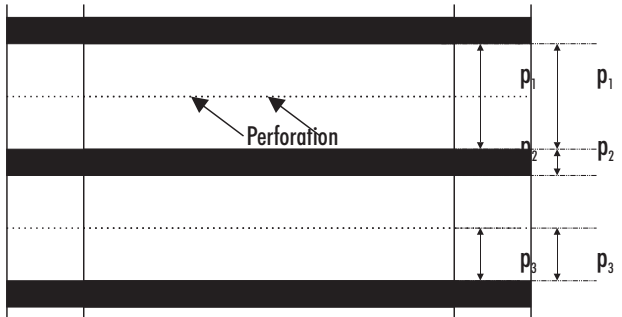

Where: Where:

$p_1 = 31.0 \text{ mm}$ (248 dots)

$p_2 = 7.0 \text{ mm}$ (56 dots)

$p_3 = 17 \text{ mm}$ (136 dots)

The Q command would be:

Q248,B56-136↵

r Command - Set Double Buffer Mode

Description: Use this command to disable or reenable the double buffer image (label) printing. The double buffer feature is a automatically tested and set by the **q** and **Q** commands.

Mobile printers, such as the TR 220, ignore this command and automatically set the printer to single buffer mode.

Syntax: **rp₁**

Parameters: **p₁** = **N** - Disable Double Buffer Mode
Y - Re-enable the Double Buffer Mode if the printer memory supports the image buffer size set by **Q** and **q** parameters



The **rN** command must follow the **q** and **Q** commands in a form (label) program.



Verify the image buffer status with the **U** command(s). See page 2-2, for a sample of the Dump Mode Printout.

R Command - Set Reference Point

Description Use this command to move the reference point for the X and Y axes. All horizontal and vertical measurements in other commands use the setting for **R** as the origin for measurements. Use the **R** command as an alternative to sending the **q** command to position (center) labels that are narrower than the print head.

Syntax **R***p₁*,*p₂*

Parameters **p₁** = Horizontal (left) margin measured in dots.

p₂ = Vertical (top) margin measured in dots.

The **R** command interacts with image buffer setting, as follows:

- The **R** command forces the printer to use the full width of the print head as the width of the image buffer. The **R** command overrides the **q** commands print width setting.
- Rotate the image buffer with the **Z** command to establish top and left margins (**ZT**) or the bottom and right margins (**ZB**).
- When positioned correctly, prevents printing off two (2) edges of the label opposite the **0,0** reference point.



Use the **Q** and **R** commands together for the easiest method of positioning form elements in the print image in left aligned printers: 2746, 2746e, TLP2046 and 2344 (Eclipse).



Repeated printing off the edge of the label can cause excessive print head wear.

S Command - Speed Select

Description Use this command to select the print speed.

Mobile printers, such as the TR 220, ignore this command and automatically set speed to optimize battery use.

Syntax Sp₁

Parameters p₁ = Speed select value.

Model	Value	Speed
2722 2742 3742 3842	0 1 2	1.0 ips (25 mm/s) 1.5 ips (37 mm/s) 2.0 ips (50 mm/s)
2824 2844	1 2 3 4	1.5 ips (37 mm/s) 2.0ips (50 mm/s) 2.5 ips (63 mm/s) 3.5 ips (83 mm/s)
2443 (Orion)	1 2 3	1.5 ips (37 mm/s) 2.0ips (50 mm/s) 2.5 ips (63 mm/s)
2746 2746e 2348 Ht-146	2 3 4 5 6	2.0 ips (50 mm/s) 3.0 ips (75 mm/s) 4.0 ips (100 mm/s) 5.0 ips (125 mm/s) 6.0 ips (150 mm/s)
2684 (Strata)	1 2 3 4	1.0 ips (25 mm/s) 2.0 ips (50 mm/s) 3.0 ips (75 mm/s) 4.0 ips (100 mm/s)

Example: S2↓ :selects 2 ips (50 mmps)

TD Command - Date Recall & Format Layout

Description Use this command to define the date format and print date data. The **TD** variable is inserted within a Text or Bar Code command's **DATA** parameter to print the date. The **TD** variable supports offsetting day by up to 253 days (see examples below for usage).



This command only works in printers equipped with the Real Time Clock time and date option.

Syntax **TD****p**₁[|**p**₂|**p**₃]

Parameters **p**₁, **p**₂, **p**₃ = The parameters describe the format of the date display. At least one parameter must be supplied. Each parameter can be any of the acceptable values listed below.

Value	Description
y2	Year displayed as 2 digits (95)
y4	Year displayed as 4 digits (1995)
me	Month displayed as 3 letters (JAN)
mn	Month displayed as 2 digits (01)
dd	Day displayed as 2 digits (15)

| = Separator character. The separator may be any ASCII character value between 032 and 063. The separator character is printed between the results of each of the supplied parameters.

Power-Up Default Format - **mn-dd-y4**

Examples: If the current date is January 15, 2000:

TDy2/me/dd↓ :00/JAN/15
TDdd-me-y4↓ :15-JAN-2000
TDdd,mn,y4↓ :15,01,2000

TDdd/me/y2 :15/09/00
A100,100,0,4,1,2,N,"Today is"TD :Today is 15/09/00
A100,200,0,4,1,2,N,"Next Week-"TD+07 :Next Week-22/09/00
A100,300,0,4,1,2,N,"Next Month-"TD+30 :Next Month-15/10/00
A100,400,0,4,1,2,N,"Two Months-"TD+61 :Two Months-15/11/00

TS Command - Set Real Time Clock

Description Use this command to set the time and date in printers equipped with the Real Time Clock option.

Syntax **TS***p*₁,*p*₂,*p*₃,*p*₄,*p*₅,*p*₆

Parameters **p**₁ = Month
Range: **01 to 12**

p₂ = Day
Range: **01 to 31**

p₃ = Year
Last two digits of Year (e.g. 95)
Range: Years 1991- 1999 = **90-99**
Years 2000- 2090 = **00-89**

p₄ = Hour in 24 hour format
Range: **00 to 23**

p₅ = Minutes
Range: **00 to 59**

p₆ = Seconds
Range: **00 to 59**

Example: TS01,01,95,01,00,00 : sets the date to Jan. 1, 1995
: and the time to 1:00 a.m.
TS12,31,01,15,31,00 : sets the date to Dec. 31, 2001
: and the time to 3:31 p.m.

TT Command - Time Recall & Format Layout

Description Use this command to define the time format and print time data. The **TT** variable is inserted within a Text or Bar Code command's **DATA** parameter to print the time.



This command works only in printers equipped with the Real Time Clock (RTC) time and date option.

Syntax **TT** P_1 **[** P_2 **|** P_3 **][+]**

Parameters **P₁**, **P₂**, **P₃** = **h**, **m**, or **s**

These parameters describe the format of the time display.

- At least one parameter must be supplied.
- Each parameter can be any of the values **h**, **m**, or **s** and are described below.

Value	Description
h	Hours displayed as 2 digits (e.g. 01)
m	Minutes displayed as 2 digits (e.g. 15)
s	Seconds displayed as 2 digits (e.g. 00)

[+] = Enable 12 Hour clock format
Appending a + to the end of the command string selects 12 hour clock mode. The times will display with an “AM” or “PM” indicator. **Default** (no +) = **24 hour clock mode**

| = Separator character
The separator may be any ASCII character value between 032 and 063. The separator character is printed between the results of each of the supplied parameters.

Power-Up Default Format - h:m:s

Examples: If the current time is 1:25 p.m.:

```
TT:h:m:s+↵      : 01:25:00
TT:h,m↵         : 13,25
TT:h+↵         : 01 PM
```

U Command - Print Configuration (General)

Description Use this command to print the current printer configuration for page mode printing. The printout is the same the Dump Mode printout initiated by the printer's AutoSense routine. The printer does not enter Dump Mode.

See page 2-2 for a description of this printout.

Syntax U

Example: U↵

Will Produce:

```
4" Is-237 V4.03.50XF 039
Serial port:96,N,8,1
Page Mode 200dpi USB
~~~~~
Image buffer size:0507K
Fmem:001.0K,060.4K avl
Gmem:006K,0587K avl
Emem:000K,0587K avl
I8,1,001 rY JF
S6 D07 R032,000 ZT US WY
q0832 Q1010,026
Option:
08 10 12

Date:04-09-98
Time:20:06:25
```

UA Command - Enable Clear Label Counter Mode

Description This command sets the printer to clear (empty) the print buffer if a media out condition is detected.

Syntax UA

A power cycle, reset, or **UB** command will clear this setting.

Normal (default) operation for the printer is to resume printing if the empty roll is replaced with new roll (or ribbon) and finish print any labels in the process of printing prior to a media out condition, including batch print jobs.

Example: UA↵

UB Command - Reset Label Counter Mode

Description Use this command to clear the **UA** command and restore the default setting to allow the printer to resume printing a batch job if a paper empty occurs. The page mode (EPL2) printer, by default, will resume printing if the empty roll is replaced with new roll (or ribbon) and finish a batch print job.

Syntax **UB**

Example: UB↵

UE Command - External Font Information Inquiry

Description This command will cause the printer to send information about external fonts currently stored in the printer back to the host.

Syntax **UE**

The printer will send the number of external fonts stored and each font's name, height and direction, to the host through the RS-232 port.

Example: UE↵

Will Produce: ### :number of external fonts
A,xxx,y :first font
... :A=fontname
... :xxx=font height in dots
... :y=direction (0=0°, 1=90°, 2=both)
A,xxx,y :last font

UF Command - Form Information Inquiry

Description This command will cause the printer to send information about forms currently stored in the printer back to the host.

Syntax **UF**

The printer will send the number of forms stored and each form's name to the host through the RS-232 port.

Example: UF↵

Will Produce: ### :number of forms
FORMNAME1 : first form name
FORMNAME2 :second form name
...
FORMNAME_n :last form name

UG Command - Graphics Information Inquiry

Description This command will cause the printer to send information about graphics currently stored in the printer back to the host.

Syntax **UG**

The printer will send the number of graphics stored and each graphic's name to the host through the RS-232 port.

Example: UG↵

Will Produce: ### : number of graphics
GRAPHICNAME1 : first graphic name
GRAPHICNAME2 : second graphic name
...
GRAPHICNAME_n : last graphic name

UI Command - Host Prompts/Codepage Inquiry

Description This command will cause the printer to enable prompts to be sent to the host and it will send the currently selected codepage to the host through the RS-232 port.

This command also disables software flow control (XON/XOFF). Hardware flow control is not disabled (DTR/CTS). To restart software flow control a reset (^@ command) or power must be recycled.

Syntax **UIp₁.p₂.p₃**

The printer will send information about the currently selected code page back to the host in the following format:

p₁ = Number of data bits.

p₂ = Code page.

p₃ = Country code.



The KDU automatically sends this command each time power is applied.

Example: UI₁

See Also: **I** and **U** commands.

UM Command - Codepage & Memory Inquiry

Description This command will cause the printer to **send to the host** the currently selected codepage and memory status through the RS-232 port.

This command also disables software flow control (XON/XOFF). Hardware flow control is not disabled (DTR/CTS). To restart software flow control a reset (^@ command) or power must be recycled.

Syntax **UM**
The printer will send information about the currently selected code page and memory status back to the host in the following format:

UM**p₁,p₂,p₃,p₄,p₅,p₆,p₇,p₈**

p₁ = Image buffer size in KBytes.

p₂ = Form memory allocation size in KBytes.

p₃ = Form memory free in KBytes.

p₄ = Graphic memory allocation size in KBytes.

p₅ = Graphic memory free in KBytes.

p₆ = External font memory allocation size in KBytes.

p₇ = External font memory free in KBytes.

p₈ = Appends a response in the **UI** command data format. See **UI** command on page 3-107.

Example: UM↵

See Also: **I, M, U, UI** and **UP** commands.

UN Command - Disable Error Reporting

Description Cancels **US** command

Syntax **UN**

UP Command - Codepage & Memory Inquiry/Print

Description This command will cause the printer to **print and send** the currently selected codepage and memory **status to the host** through the RS-232 port.

This command also disables software flow control (XON/XOFF). Hardware flow control is not disabled (DTR/CTS). To restart software flow control a reset (^@ command) or power must be recycled.

Syntax UP

The printer will send information about the currently selected code page and memory status back to the host followed by printing the current printer configuration. For an example of the configuration printout, see the **U** command.

The format of data sent to the host is as follows:

UPp₁,p₂,p₃,p₄,p₅,p₆,p₇,p₈,p₉

p₁ = Image buffer size in KBytes.

p₂ = Form memory allocation size in KBytes.

p₃ = Form memory free in KBytes.

p₄ = Graphic memory allocation size in KBytes.

p₅ = Graphic memory free in KBytes.

p₆ = External font memory allocation size in KBytes.

p₇ = External font memory free in KBytes.

p₈ = Appends a response in the **UI** command data format. See **UI** command on page 3-107.

Example: UP↵

See Also **I**, **M**, **U**, **UI** and **UM** commands.

UQ Command - Configuration Inquiry

Description Use this command to send the printer configuration information back to the host via the serial port.

Syntax **UQ**

The printer will send the printer configuration, line by line, in ASCII to the host through the RS-232 port. The information matches the configuration information printed in final phase of the printer's AutoSense routine, the Dump Mode Printout or the **U** command printout.

The information and number of lines of data sent by the printer will vary from printer to printer depending upon the type of printer and options installed.

Example: UQ↵

US Command - Enable Error Reporting

Description Use this command to enable the printer's status reporting feature.

- **Serial Port** - If an error occurs, the printer will send a NACK(0x15), followed by the error number, to the computer. If no errors occur, the printer will echo ACK(0x6) after each **P** command.

If paper or ribbon empty occurs, the printer will send, through the serial port, a"-07" and "Pnnn" where nnn is the number of labels remaining to print.

- **Parallel Port** - If an error occurs, the printer will print the error number and the printer's indicator(s) LED will indicate an error condition. See the individual printer user's manual for details.
- **Mobile Printers Only** (TR220) - *Additionally enables command error reporting via printer's status indicator. The indicator is turned off by default for this printer only.*

Syntax **US**[p₁]

The printer's default setting is disabled error reporting.

Parameters **p₁ = 1** **Optional Parameter**

If no errors occur, the printer will echo ACK(0x6) after each label that is successfully printed.

Use the **UN command to disable error reporting.**

US Command - Enable Error Reporting

Code	Error/Status Description
00	No Error
01	Syntax Error
02	Object Exceeded Label Border
03	Bar Code Data Length Error (e.g.: EAN-13 is a 12 or 13 digit only)
04	Insufficient Memory to Store Data
05	Memory Configuration Error
06	RS-232 Interface Error
07	Paper or Ribbon Empty
08	Duplicate Name: Form, Graphic or Soft Font
09	Name Not Found: Form, Graphic or Soft Font
10	Not in Data Entry Mode
11	Print Head Up (Open)
12	Pause Mode or Paused in Peel mode
13	Mobile Printers: Print head too hot
14	Mobile Printers: Motor too hot
15	Mobile Printers: Battery low warning ($\geq 40\%$)
16	Mobile Printers: Battery low limit ($\geq 20\%$)
50	Does not fit in area specified
51	Data length to long
84	Media Error or Blackline not detected
93	PDF-417 coded data to large to fit in bar code

U% Command - Host Prompts/Motor Temperature

Description EPL Mobile Printers Only (TR 220) - This command will cause the printer to **send to the host** the motor temperature status through the mobile printer's serial port.

Syntax U%

The printer will send motor temperature in 2°C increments to the host via the serial port. The printer uses the data format of **NNdeg C**, where **NN** equals the motor temperature.

Range Reported (Degrees Celsius): $24 \leq \text{NN} < 60$

U%



EPL Mobile printers suspend printing operations, including printer to host communication, until the motor returns to safe operating temperatures.

The mobile printer will stop printing at 60°C or higher.

The printer will resume printing at 50°C.

Example: U%
↓

: Command sent to printer

: Printer responds with motor temperature

: **24 deg C**

U\$ Command - Host Prompts/Battery Status

Description Mobile Printers Only (TR 220) - This command will cause the printer to **send to the host** the battery charge status.

Syntax **U\$**

The printer will send information about battery charge status in increments of 10 percent. The printer uses the data format of **VccNNN%**, where **NNN** represents the battery's charge level.



EPL Mobile printers suspend all new printing operations, including printer to host communication, until the battery charge level is greater than 10%.

Print jobs or forms (single label or batch operations) will continue processing until finished.

The mobile printer will accept new commands and print after the battery charge is greater than 10%.

Example: U\$↵

: Command sent to printer
: Printer responds with
: **Vcc90%**

V Command - Define Variable

Description Use this command to define variable data for the text and bar code data fields in stored forms. Variable data can be combined with fixed data or other data types (counter, date, etc..) in text or bar code data fields.

Syntax **V***p*₁,*p*₂,*p*₃,"[-]**PROMPT**"

Parameters **p**₁ = Variable number.
Range: **00 to 99** .
Variable (reference) numbers are sequential and must be input into a form in ascending order.

p₂ = Maximum number of characters
Range: **1 to 99** .
This is the maximum number of characters allowed in the variable field.

p₃ = Field Justification.
L = Left **R** = Right
C = Center **N** = No Justification
Note: *Right and center justification does not apply to soft fonts.*

"PROMPT" = An ASCII text field that will be transmitted to the host (via the serial interface) each time this command is executed.

Use the prompt to ask for a value to be entered for the variable.

KDU Options [-] = Having the first character of the prompt a single minus sign will cause the prompt to display only once after form retrieval.

KDU Character Number Limit The KDU allows a maximum of 40 characters for entry into a variable data field and display.

KDU Range (**p**₂): **1 to 40**, but not to exceed a total of 1500 bytes for all variables.

V Command - Define Variable

Use this command in forms that require unique data on each label. When initializing variables:

- They must be defined in order (e.g. **V00** first, **V01** second...)
- They must be the next entries after the **FS"FORMNAME"** command
- They must be located before any counter variables.
- Variables must not contain the NULL character (0 dec.;00 hex.). The NULL character is an illegal text character.

To print the contents of the variable, the variable number is referenced in the **"DATA"** field of the **A** (ASCII text) or **B** (Bar Code) commands.

The field justification parameter effects the way the variable will be printed. When **L** or **R** are selected, the variable value will be printed left or right justified in an area with a width defined by **P₂** parameter.



The maximum amount of data stored as variable data, including counter variables and data reference overhead can not exceed 1500 bytes.



KDU Support: Internally stored variable data fields are reset after cycling printer power or sending a re-set command or pressing the Cancel.

Example: V00,15,N,"Enter Product Name:" ↵

W Command - Windows Mode

Description This command is used to disable/re-enable the Windows command mode.

Syntax **Wp₁**

Parameters **p₁** = Windows Mode Enabled.
Values = **Y** for enabled (default)
N for disabled

When enabled, the printer will accept Windows mode escape sequences to print data. When disabled, escape sequences will be ignored.

The Windows mode escape sequences are only used by the optional Windows printer driver. When working with a main frame or other non-Windows host, this mode can be disabled to prevent erratic operation.

xa Command - AutoSense

Description This command is used to have the printer detect the label and gap length and set the sensor levels. This command will not enter into the Dump mode or print the printer configuration label.

Syntax xa ↵

Example: xa ↵

:The printer will feed labels and
: measure the labels to set the Q values
:(label & gap length) and the sensor
: levels.
: The printer is at Top of Form (TOF)
: and ready to print .

X Command - Box Draw

Description Use this command to draw a box shape.

Syntax **X****p**₁,**p**₂,**p**₃,**p**₄,**p**₅

Parameters

p₁ = Horizontal start position (X) in dots.

p₂ = Vertical start position (Y) in dots.

p₃ = Line thickness in dots.

p₄ = Horizontal end position (X) in dots.

p₅ = Vertical end position (Y) in dots.

Example: N↵
X50,200,5,400,20↵
X200,50,10,20,400↵
P1↵

Will Produce:

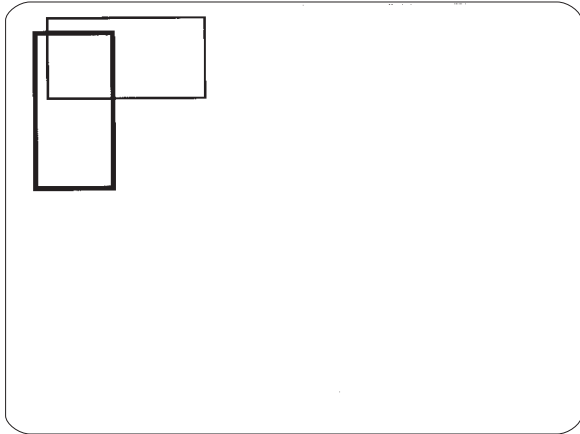

Y Command - Serial Port Setup

Description Use this command to establish the serial port communication parameters.

Syntax **Y****p**₁,**p**₂,**p**₃,**p**₄

Parameters **p**₁ = Baud rate

p ₁	Description
38	38,400 baud (38K)
19	19,200 baud
96	9,600 baud
48	4,800 baud
24	2,400 baud
12	1,200 baud

p₂ = Parity.
Values: **O** = Odd parity
E = Even parity
N = No parity

p₃ = # Data bits.
Values: **7** = Seven data bits
8 = Eight data bits

p₄ = # Stop bits.
Values: **1** = One stop bit
2 = Two stop bits.

After receiving this command, the printer will automatically reset enabling the new rate.



To send commands and data to the printer, the host's serial port parameters must match the printer's serial port parameters. Verify the printer's configuration settings with the AutoSense/Dump Mode Printout, see the printer's user's manual for details.

**The printer's default serial port parameters are:
9600 baud, No Parity, 8 Data Bits, 1 Stop Bit**

Change the printer's serial port parameters with the **Y** command after communication has been established with the host. The host parameters must then be changed to resume communication.

Example: Y19,0,7,1 ↵ :sets 19,200 baud, odd parity,
:7 data bits and 1 stop bit.

Z Command - Print Direction

Description Use this command to select the print orientation.

Syntax **Zp₁**

Parameters **p₁** = Print orientation.
T = Printing from top of image buffer.
B = Printing from bottom of image buffer.
Default Orientation = **T**



The top of the image buffer prints first and is viewed by the operator as printing up side down.

Example: N↵
ZT↵
GG10,10,"WORLD"↵
A10,200,0,3,1,1,N,"This Graphic Was Printed With Orientation Set To ZT"↵
PT↵
N↵
ZB↵
GG10,10,"WORLD"↵
A10,200,0,3,1,1,N,"This Graphic Was Printed With Orientation Set To ZB"↵
PT↵

Will Produce:

↑
Print Direction

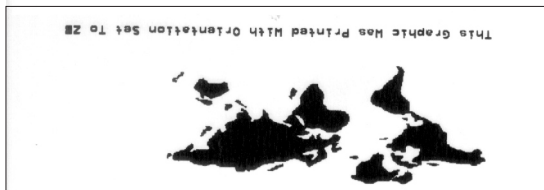
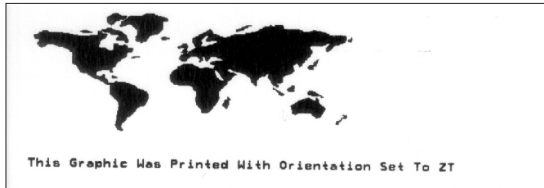

? Command - Download Variables

Description This command signals the printer to “fill-in” variable or counter “prompt” data field.

The host system can send data representing variables and/or counters to the printer after a stored form containing variables and/or counters has been retrieved.

Syntax ? DATA

The amount of data following the question mark line must match exactly the order and total number of variables and/or counters for that specific form.

Data must be entered, as follows:

- Each **DATA** line represents a variable or counter data field fill-in.
- Variables in ascending order (e.g. **V00** first, **V01** second...)
- Counters in ascending order following Variables (e.g. **C0** first, **C1** second...)

Example

```
FK"form1"␣ :delete form "form1"  
FS"form1"␣ :begins the form store  
V00,15,N,"Enter Part Name:"␣  
V01,5,N,"Enter Quantity:"␣  
A50,10,0,3,1,1,N,V00␣  
A50,400,0,3,1,1,N,"Quantity: "V01␣  
FE␣ :ends form store sequence
```

```
FR"form1"␣ :retrieve for "form1"  
?␣ :variables follow  
Screws␣ :first variable  
235␣ :second variable  
P1␣ :print one label
```

^@ Command - Reset Printer

Description This command is used to reset the printer.

Syntax ^@↵ :where ^ is 94 decimal

This command emulates Power Off and then Power On; thus reinitializing the printer.

- The reset command is unavailable during the operation of storing PCX graphics, soft fonts or while the printer is in dump mode.
- The reset command cannot be used in a stored form.
- The reset command can be sent to the printer during all other printing operations.
- The printer will ignore all commands sent while the reset command is executing, up to 2 seconds.

Example: ^@↵ :The printer will reset

^ default Command - Set Printer to Factory Defaults

Description: Use this command to return the printer to its default configuration.

The **^ default** command resets the density, speed, sensors, image buffer parameters, character code page (including re-mapped characters), options, feed button behaviors, gap mode media sensing, serial interface configuration, error reporting and line mode configuration defaults.

This command is intended for troubleshooting and by service organizations. Do not use this command in regular programming! Do not use this command to initialize the printer! This overwrites all stored parameters. The programmer should always minimize writing to the non-volatile 'flash' printer memory.

Supported by firmware versions 4.30 and above.

Syntax: **^ default**

Parameters: **None**

^ee Command - Error Report - Immediate

Description: Use this command to get printer error and status report immediately. The ^ee command must be sent via the RS-232 serial interface.

Mobile printers, such as the TR 220, ignore this command.

The printer will report 4 bytes back to host in the following format:

XX<CR><LF>

XX = Error/Status code
<CR> = Carriage Return (ASCII 13 dec.)
<LF> = Line Feed (ASCII 10 dec.)

Syntax: ^ee

Parameters: None

Code	Error/Status Description
00	No Error
01	Syntax Error
02	Object Exceeded Label Border
03	Bar Code Data Length Error (e.g.: EAN-13 is a 12 or 13 digit only)
04	Insufficient Memory to Store Data
05	Memory Configuration Error
06	RS-232 Interface Error
07	Paper or Ribbon Empty
08	Duplicate Name: Form, Graphic or Soft Font
09	Name Not Found: Form, Graphic or Soft Font
10	Not in Data Entry Mode (See ? Command)
11	Print Head Up (Open)
12	Pause Mode or Paused in Peel mode
50	Printer Busy - Processing Print Job
80*	Undefined
81*	Cutter Jammed or Not Installed
82*	AutoSense or Sensor Failure
83*	Illegal Interrupt occurred
84*	Excessive Media Feeding

* - Requires Intervention: Press Feed or Reset (^@ command)

; Command - Code Comment Line

Description This command signals the printer to ignore the following data. All data between the line initiating semicolon character (**;**) and the next line feed (**LF**) character (which terminates all command lines) will be ignored.

Supported by firmware versions 4.30 and above.

Syntax **;** Comment data

Example

```
; This is used for xxxXXX␣ : "This is used for xxxXXX"  
                           : is ignored by the printer.
```

Appendix A - Character References

This section has character references.

Resident Fonts 1-5 Page Mode supports 5 different font sizes, numbered 1-5. Each font can be expanded both horizontally and vertically. All fonts are non-proportional, mono-spaced. The ASCII value of each character is dependent on the **I** command character set (code page) selection.

1. ABCDEFGHIJKLMNOPQRSTUVWXYZabcdefghijklmnopqrstuvwxyz
0123456789 !@#\$%^&*()_+<>?[]::

2. ABCDEFGHIJKLMNOPQRSTUVWXYZabcdefghijklmnopqrstuvwxyz
0123456789 !@#\$%^&*()_+<>?[]::

3. ABCDEFGHIJKLMNOPQRSTUVWXYZabcdefghijklmnopqrstuvwxyz
0123456789 !@#\$%^&*()_+<>?[]::

4. ABCDEFGHIJKLMNOPQRSTUVWXYZabcdefghijklmnopqrstuvwxyz
0123456789 !@#\$%^&*()_+<>?[]::

**5. ABCDEFGHIJKLMNOPQRST
0123456789 # \$ % &**

Default Character Map Code Page - 437

0	16	32	48	@	P	'	p	Ç	É	á	160	176	192	208	224	240
1	17	33	49	1	A	Q	a	q	ü	æ	í				ß	
2	18	34	50	2	B	R	b	r	é	ø					Γ	
3	19	35	51	3	C	S	c	s	â	ô	ú				Π	
4	20	36	52	4	D	T	d	t	ä	ö	ñ				Σ	
5	21	37	53	5	E	U	e	u	à	ò	Ñ				σ	
6	22	38	54	6	F	V	f	v	ä	ü	ä				μ	
7	23	39	55	7	G	W	g	w	ç	ù	°				Τ	
8	24	40	56	8	H	X	h	x	ê	ÿ	ç				Θ	°
9	25	41	57	9	I	Y	i	y	ë	ö					Θ	°
10	26	42	58	10	J	Z	j	z	è	Ü					Ω	
11	27	43	59	11	K	[k	{	ï	ç	½				δ	
12	28	44	60	12	L	\	l]	î	£	¼				δ	
13	29	45	61	13	=	M]	m	ï	¥	ı				ø	¿
14	30	46	62	14	>	N	^	n	Ä						€	
15	31	47	63	15	?	O	_	o	Å	š						

Fonts 1-4 are represented by the shaded and unshaded cells and Font 5 only supports shaded cells.

See the **I** command to for more information on selecting available code pages, page 3-63. The electronic manual version on the user's CD includes links to the individual code pages.

Euro Character Page mode printing supports the Euro character with a character substitution command, the **oR** command. The Font 5 character set does not support the typical implementation of the Euro character position at 213 decimal (D5 hexadecimal).

Dump Mode Character Map The printer's Dump Mode is used to troubleshoot programming. The printer will print all data as sent in Dump Mode Characters, shown below.

Hexidecimal - Most Significant Digit

		0	1	2	3	4	5	6	7	8	9	A	B	C	D	E	F	
Hexidecimal - Least Significant Digit	0	00 0	▶		0	@	P	'	p	€	•		°	À	Ð	à	ð	
	1	01 1	☺	◀	!	1	A	Q	a	q	•	'	±	Á	Ñ	á	ñ	
	2	02 2	☺	↕	"	2	B	R	b	r	,	'	²	Â	Ò	â	ò	
	3	03 3	©	!!	#	3	C	S	c	s	f	“	£	³	Ã	Ó	ã	ó
	4	04 4	..	¶	\$	4	D	T	d	t	„	”	¤	'	Ä	Ô	ä	ô
	5	05 5	§	§	%	5	E	U	e	u	...	•	¥	µ	Å	Õ	å	õ
	6	06 6	ª	—	&	6	F	V	f	v	†	—	‡	¶	Æ	Ö	æ	ö
	7	07 7	•	↕	'	7	G	W	g	w	‡	—	§	•	Ç	×	ç	÷
	8	08 8	☐	↑	(8	H	X	h	x	^	~	..	•	È	Ø	è	ø
	9	09 9	○	↓)	9	I	Y	i	y	‰	™	©	ı	É	Ù	é	ù
	A	0A 10	☐	→	*	:	J	Z	j	z	Š	š	ª	°	Ê	Ú	ê	ú
	B	0B 11	G	←	+	:	K	[k	{	<	>	«	»	Ë	Û	ë	û
	C	0C 12	E	┌	,	<	L	\	l		Œ	œ	¬	¼	Ì	Ü	ì	ü
	D	0D 13	♪	↔	-	=	M]	m	}	•	•	-	½	Í	Ý	í	ý
	E	0E 14	♪	▲	.	>	N	^	n	~	Ž	ž	®	¾	Î	Þ	î	þ
	F	0F 15	C	▼	/	?	O	o	◻	•	ÿ	—	—	¿	Ï	ß	ï	256 255

Appendix B - Cash Drawer Kicker Option

This section has hardware and programming for the Cash Drawer Kicker.

Introduction The cash drawer kicker is a factory option only. The printer requires a special PCBA to support this option. At the time of publication, the 2824 printer is the only page mode printer model supporting the cash drawer kicker option. Check our web site or your dealer for further updates.

**Cash Drawer Cable
Wiring**

The figure below displays the pin assignments for the printer's retail cash drawer interface. Refer to the cash draw manufacturer's documentation for proper drawer wiring.

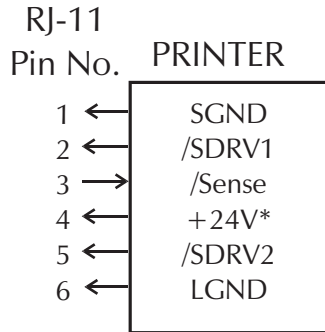

Male RJ-11

*+24 volts D.C. at no greater than 1.5 amps.

<Esc>p Command - Generate Pulse CDK

Description Generate a drawer kicker pulse.

Syntax <Esc>p**p₁** **p₂** **p₃**

Parameters **p₁** = Select Drawer
Drawer 1 (SDRV1) = 31 hex.

p₂ = Pulse width in multiples of two milli- seconds (2 msec).
Range = 00 - FF hex.

p₃ = This parameter must be present for parsing the command but the value is ignored by the printer.
Range = 00 - FF hex.

ASCII Hex Value 1B 70 **p₁p₂p₃**
(**p₁** represent value 31 hex;
p₂ represent value range 00 to FF hex;
p₃ represent value range 00 to FF hex)

Example <p1Bd␣

: <p = <Esc> p , the command
: 1 = p1 parameter value of 31 hex.
: B = p2 parameter value of 42 hex. for
: 132 msec pulse (66 x 2msec)
: d = p3 parameter value of 64 hex.
: A character is needed for command to
: be processed.

<Esc>u Command - CDK Status

Description Report the cash drawer kicker's status.

Syntax **<Esc>u**

Parameters **None**

Status **00** hex. = Cash Drawer Open

01 hex. = Cash Drawer Closed